



School of Electrical Engineering and Telecommunications &  
Real-Time Digital Simulations Laboratory (RTS@UNSW)

# Integration of Solar PV Systems: From Standards Testing to Power Hardware-in-the-Loop functional validation

**Dr. Georgios Konstantinou**  
Senior Lecturer and ARC Early Career Research Fellow  
School of Electrical Engineering and Telecommunications  
UNSW Sydney



**UNSW**  
SYDNEY

2019 RTDS Australia User Group Meeting  
Melbourne, 2-3 October 2019



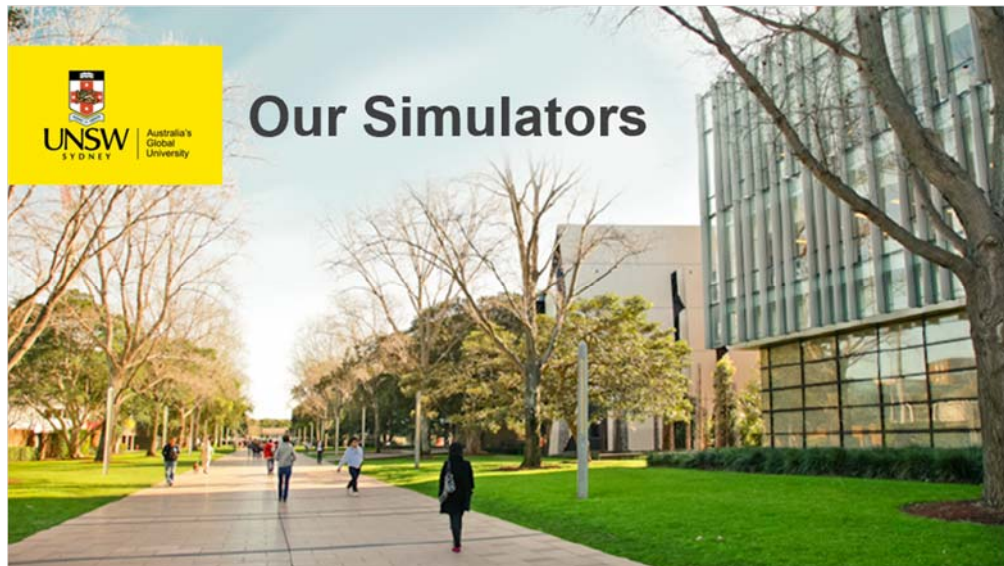

# Our Simulators



# The Challenge & Motivation



# Inverter Testing

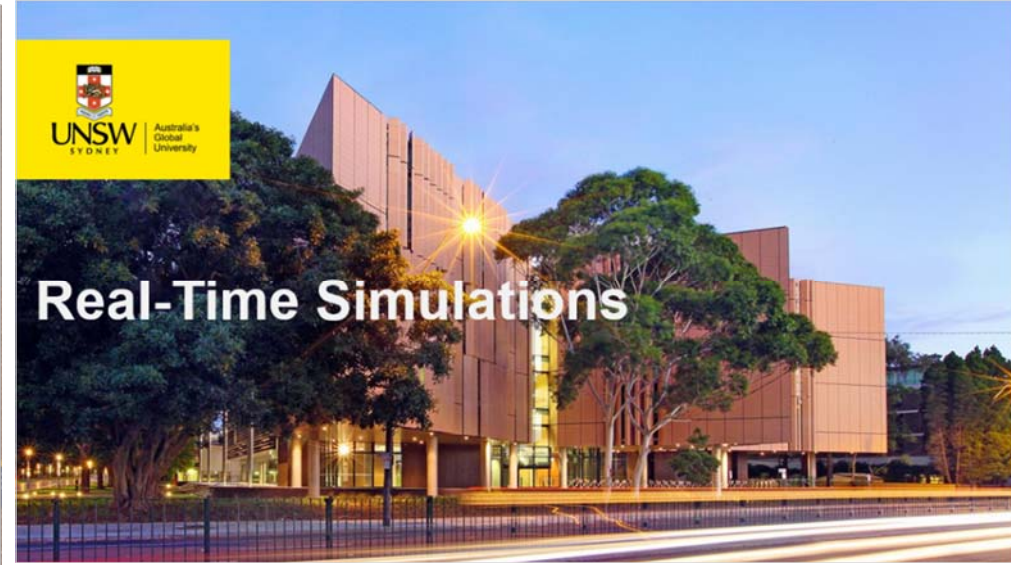

# Real-Time Simulations

# Our Simulators





# Our Simulators - RTDS

- Hosted in the Tyree Energy Technologies Building
- 18-rack RTDS System
  - 90 PB5 Processor Boards
  - 216 Analogue IOs (18 GTA0 / GTAI cards)
  - 1152 digital optically isolated IOs (18 GTDO / GTDI cards)
  - 18 GTNET cards



# Our Simulators - RTDS



# Our Simulators – Additional Hardware

- 4x Omicron CMS156 Amplifiers
- 2x Schneider Electric Easergy P3 Protection Relays
- 1x PSL microPMU

Interfaced via two optical fiber links to UNSW Power Electronics Research Laboratory for PHIL testing



# Laboratory Interoperability

GTAOs drive 3x REGATRON TC.ACS  
50kVA 4-quadrant grid simulators



- GTAs used for measurement and feedback to the RTDS
- 4x TopCon DC (10kW and 16kW) as PV emulators and dc power supplies





# PHiL capabilities - Example

Room 365 – RTS@UNSW

2 x 100 m Optical Fibre

Room 334 – Power Electronics Lab

### Simulated Network

The diagram illustrates a simulated power network with five distinct areas. Area 1 includes a PV-PP (Photovoltaic Power Plant) and a BESS (Battery Energy Storage System). Areas 2, 3, 4, and 5 contain various types of WPGS (Wind Power Generation Systems) and other power equipment. The RTDS rack in the image is the physical hardware used to simulate this network in real-time.

### MMC based MTDC System

This section shows the hardware components of the MMC-based MTDC system. The ACS unit is responsible for the real-time control of the converters. The GTAO module is a key component for the thyristor-based converter. The rack of four MMC units represents the physical multilevel converters used in the experimental setup.



# PHiL capabilities - Example

Room 365 – RTS@UNSW

2 x 100 m Optical Fibre

Room 334 – Power Electronics Lab

Simulated Microgrid /  
Distribution Grid

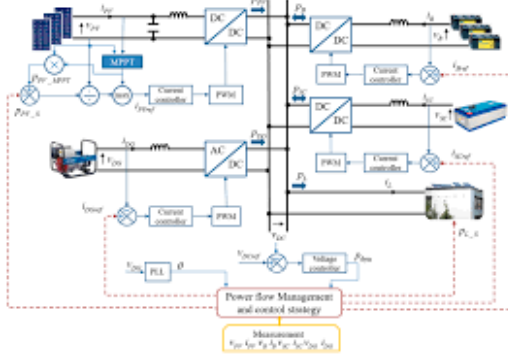

GTAO

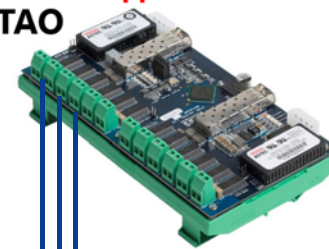

24V



Microgrid  
230 V



# PHiL capabilities - Example

Room 365 – RTS@UNSW

2 x 100 m Optical Fibre

Room 334 – Power Electronics Lab

Simulated Network

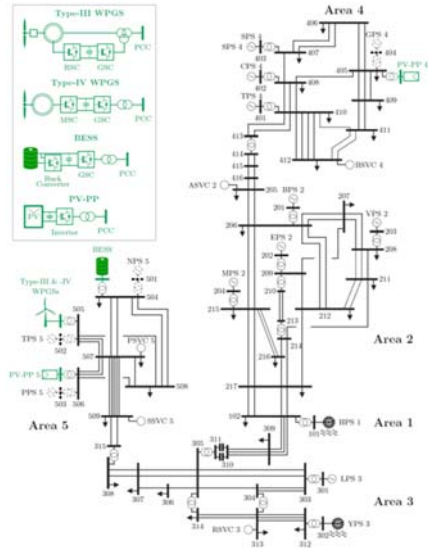

GTAO

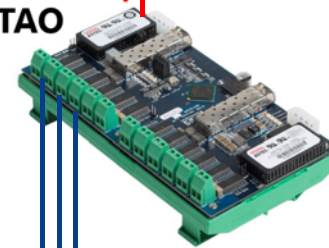

24V



230 V

Inverter under test



# The Challenge & Motivation



# QLD – SA Separation Event (August 2018)

Saturday 25 August 2018,

- A single lightning strike on a transmission tower structure supporting the two circuits of the 330 kilovolt (kV) Queensland – New South Wales interconnector (QNI) lines.
- The QLD and NSW power systems then lost synchronism, islanding the QLD region two seconds later.
  - » At the time, 870 MW of power was flowing from QLD to NSW.
  - » QLD experienced an immediate supply surplus resulting in a rise in frequency to 50.9 Hertz (Hz).
  - » The remainder of the NEM experienced a supply deficit, resulting in a reduction in frequency.



# QLD – SA Separation Event (August 2018)

- Basslink interconnector immediately increased flow from TAS to VIC from 500 MW up to 630 MW (Frequency control)
  - » This created a supply deficit in TAS (81 MW lost via UFLS)
- Heywood interconnector experienced rapid changes triggering the Emergency APD Portland Tripping (EAPT) scheme.
  - » SA separates from the NEM at Heywood, 6 seconds after QNI separation.
  - » SA frequency rises
  - » VIC / NSW frequency drops below 49 Hz triggering UFLS.
  - » A total of 997.3 MW of supply was interrupted in VIC and NSW (904 MW of smelter load in both regions and 93.3 MW of consumer load in NSW).

# Frequency across the NEM

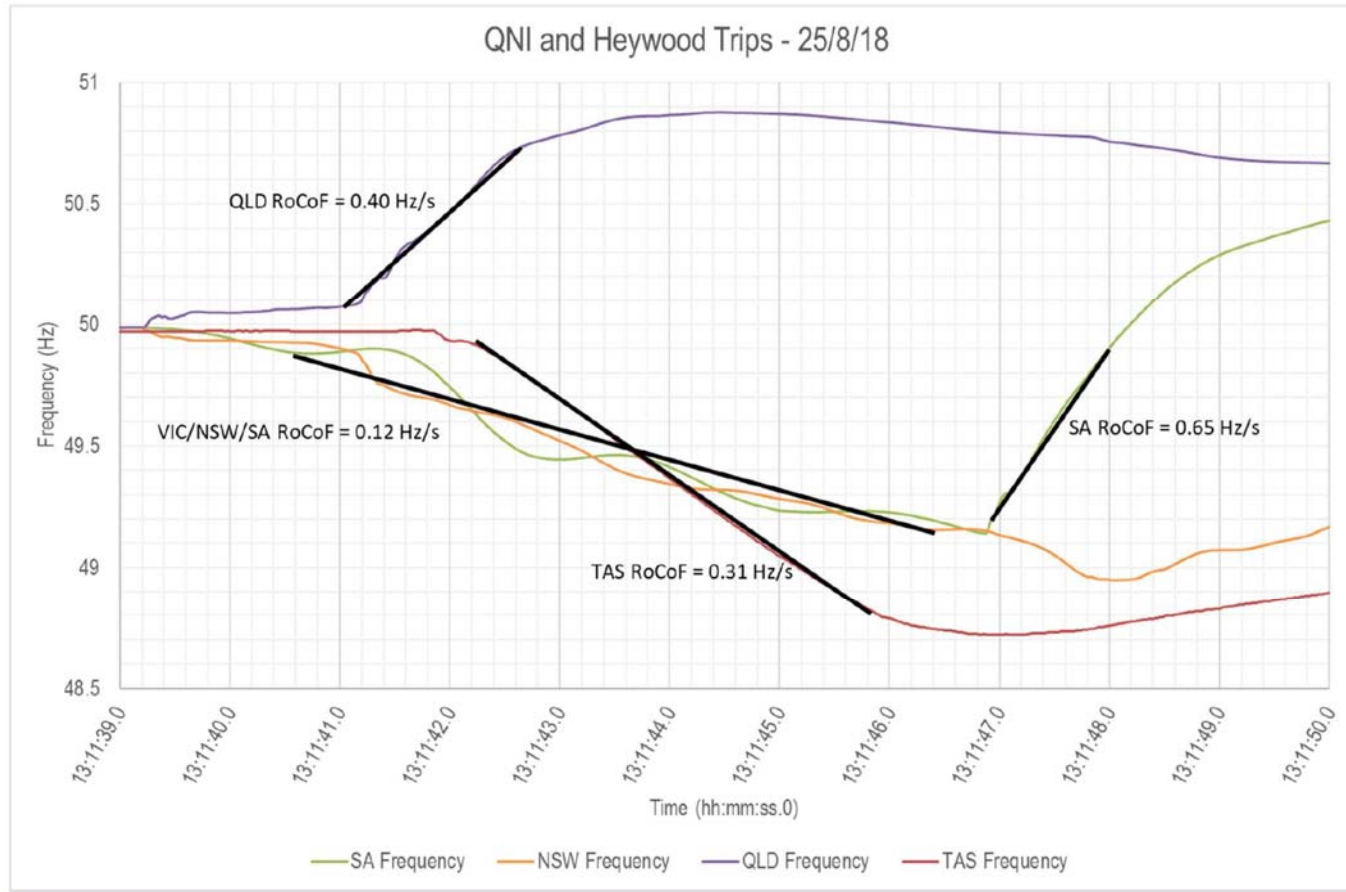



**So What?**

# Distributed Generation

At the time of the event:

- Distributed generation (mostly PV) was ~3,096 MW (Total installed ~6,300 MW).
- Total installed 2019 – Estimated > 9GW
- Over-frequency in QLD / SA
  - » Contribution by output reduction (AS4777)
- Underfrequency in VIC / NSW
  - » No provisions under current standard

Region	Output	Capacity
NSW	526 MW	1709 MW
QLD	1043 MW	2177 MW
SA	600 MW	919 MW
TAS	65 MW	124 MW
VIC	862 MW	1349 MW



# Distributed Generation

1. Approximately 15% of sampled systems installed before October 2016 dropped out during the event.
2. Of the sampled systems installed after October 2016, around 15% in QLD and 30% in SA did not provide the over-frequency reduction capability required by the applicable Australian standard.

# Distributed Generation

## SA response (Sampled)

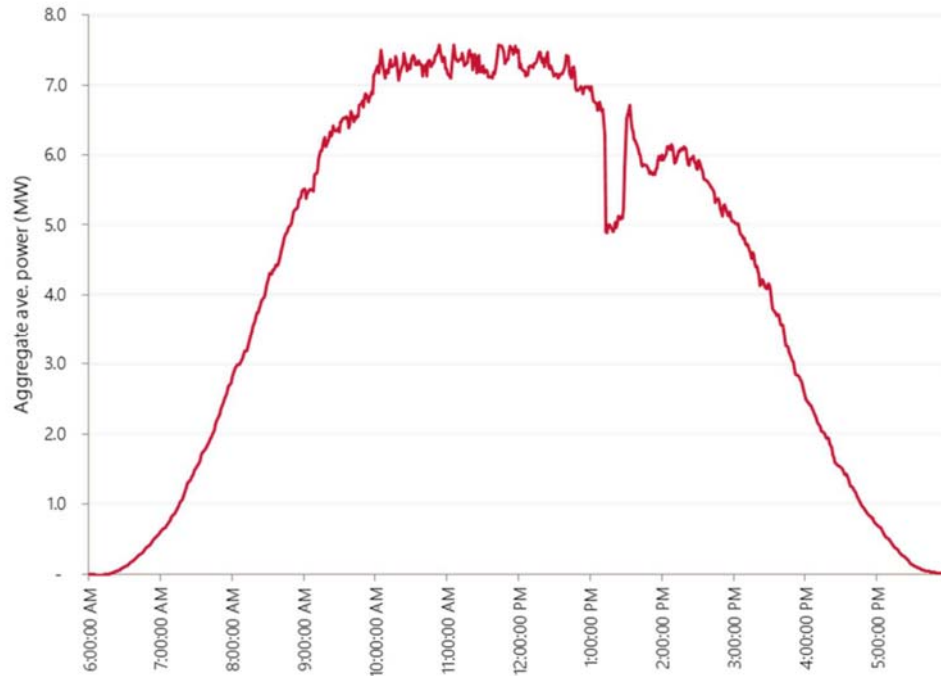

## QLD response (Sampled)

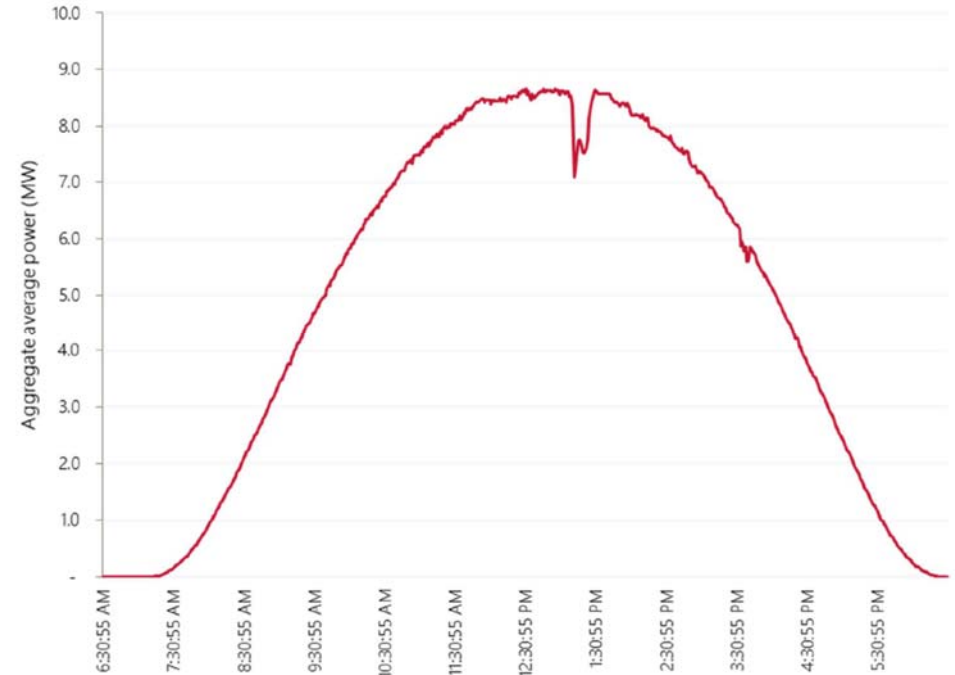

# Distributed Generation

NSW response (Sampled)

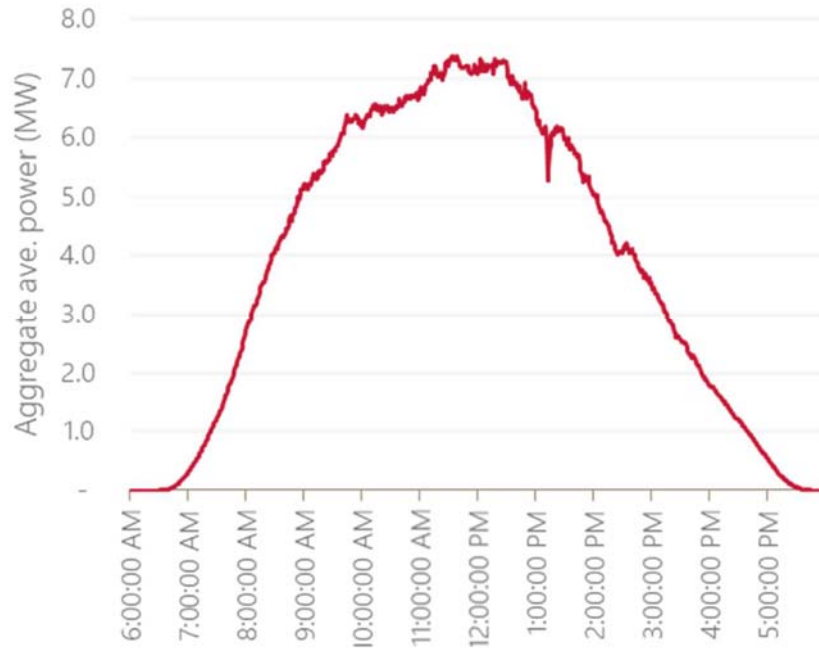

VIC response (Sampled)

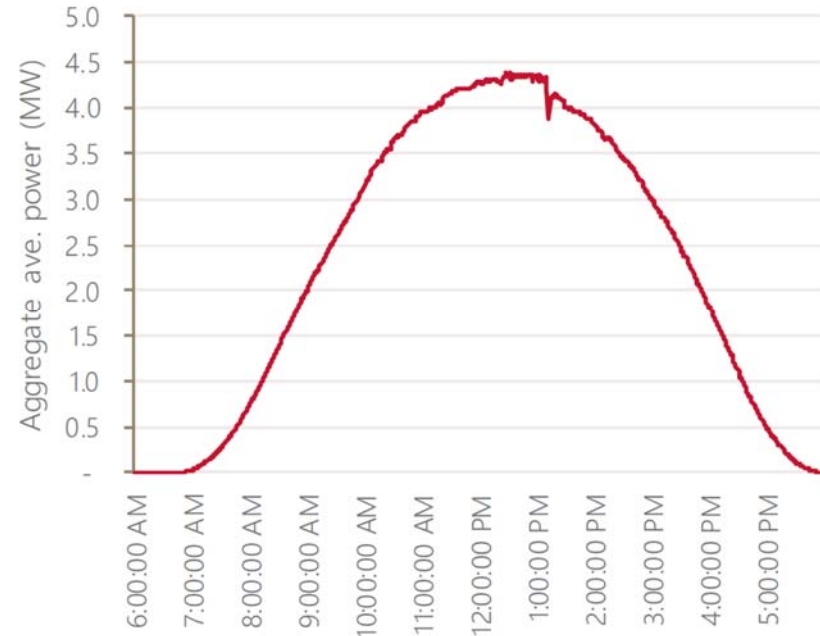

# Across the NEM?

- Scaling up\* across the NEM it is apparent that DG response will have substantial contribution during disturbances as:
  - DG penetration increases
  - System inertia decreases

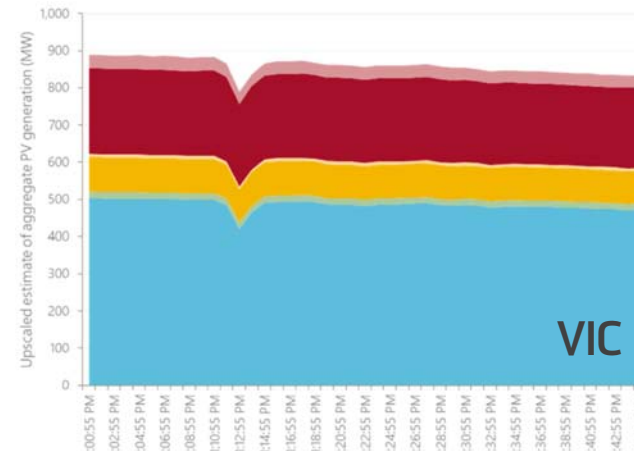
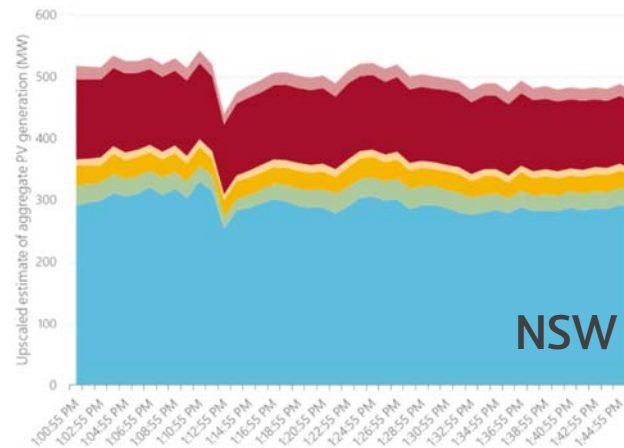
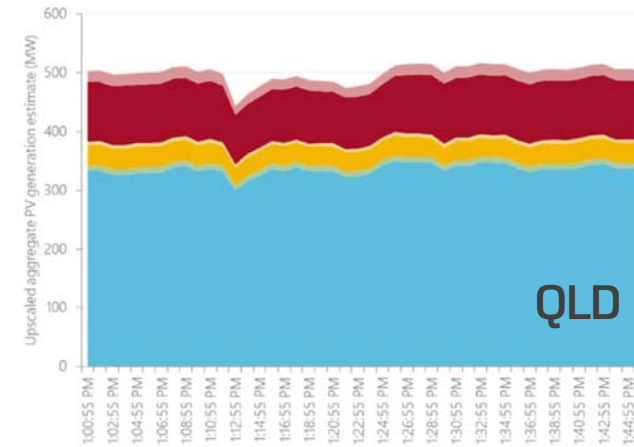
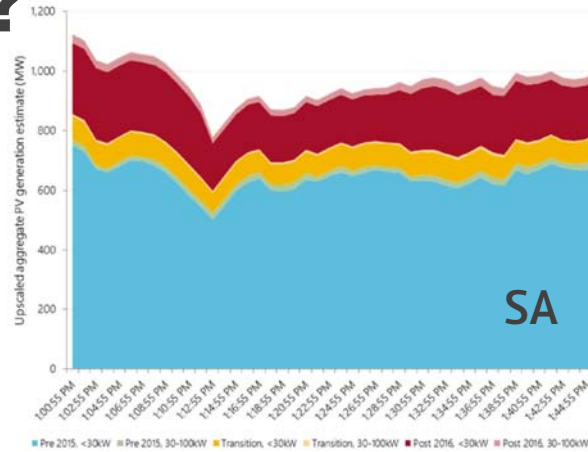



# Recommendations following the event

1. Reduce the risk of islanding regions from the NEM by reviewing and improving protection schemes and other control and protection schemes.
2. Characterize and model the **response of distributed PV to system disturbances**, including investigation of the potential benefits accessible from a distributed PV response.
3. Improve modelling of frequency response and active power control characteristics of the power system.

# UK LFDD Event (August 2019)

Similarities?

1. **Lightning strike** on a transmission circuit (the Eaton Socon – Wymondley Main).
  - The protection systems operated and cleared the lightning in under 0.1 seconds. The line then returned to normal operation after c. 20 seconds
  - Following the lightning strike and within seconds of each other
    - Hornsea off-shore windfarm reduced its output.
    - Little Barford gas power station reduced its output.
2. Unexpected loss of generation meant that the **frequency dropped very quickly** outside the normal range of 50.5Hz – 49.5Hz

# UK LFDD Event (August 2019)

3. There was **some loss of small embedded generation** which was connected to the distribution system (c. **500MW**) due to the lightning strike.

*Immediately following the lightning strike on the Eaton Socon–Wymondley circuit ~500MW of embedded generation was lost, typically this would be solar, and some small gas and diesel fired generation, due to the operation of the generation sources own protection systems (Loss of Mains Protection)*

The lightning strike initiated the **operation of Loss of Mains (LoM) protection** on embedded generation in the area and added to the overall power loss experienced.

# UK LFDD Event (August 2019)

## Recommendations:

- The amount of forecast embedded generation **that could be lost** through the LoM protection should also be considered.
  - *This loss is considered as independent of the largest infeed loss and so the response holding should cover the larger of the two but does not need to cover both events. The ESO must also consider the inertia of the system and ensure enough response to prevent operation of the RoCoF LoM protection.*
  - Protection considerations based on
    - » Change in Frequency
    - » Change in Voltage and *Vector Shift* (Phase Jump)

# UK LFDD Event (August 2019)

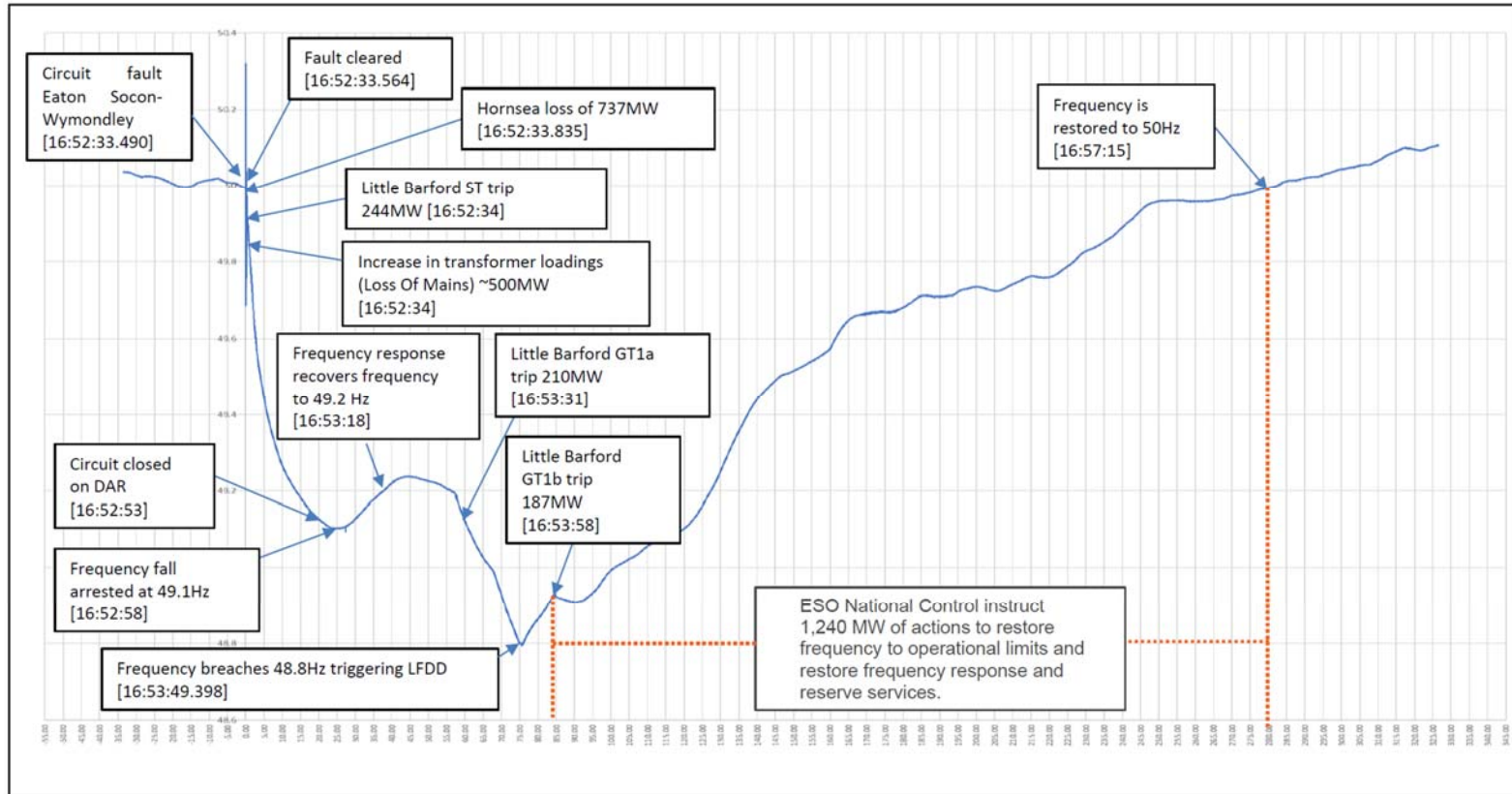





**UNSW**  
SYDNEY

Australia's  
Global  
University

# Inverter Testing



# Addressing Barriers to Efficient Renewable Integration

Aims of the project:

- Understand PV inverter behaviour during grid disturbances
- Bench testing commercial PV inverters
- Contribute to improve AS 4777.2: 2015 “Inverter requirements”
- Develop composite PV-load model closely emulating dynamics of loads with high PV penetration

# Inverter bench testing

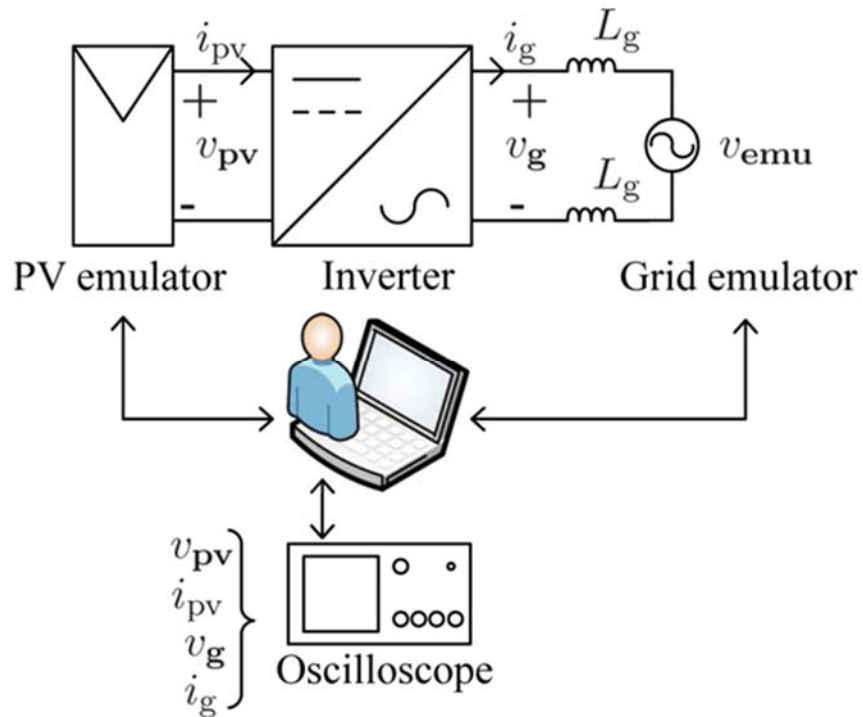

- PV emulator simulates non-linear characteristic of PV array
- Grid emulator: single phase grid voltage; ability to change frequency, phase angle, voltage amplitude
- Data are sampled at 50 kHz on digital oscilloscope and post processed using MATLAB/SIMULINK

# Possible Transient Behavior

## Fast voltage sag ride-through

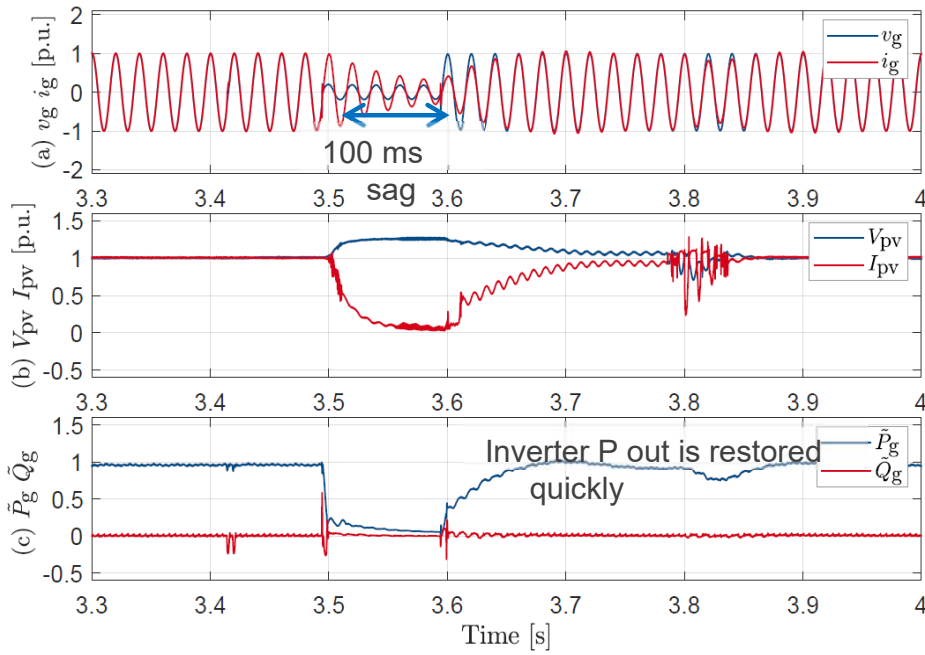

## Fast voltage sag curtailment

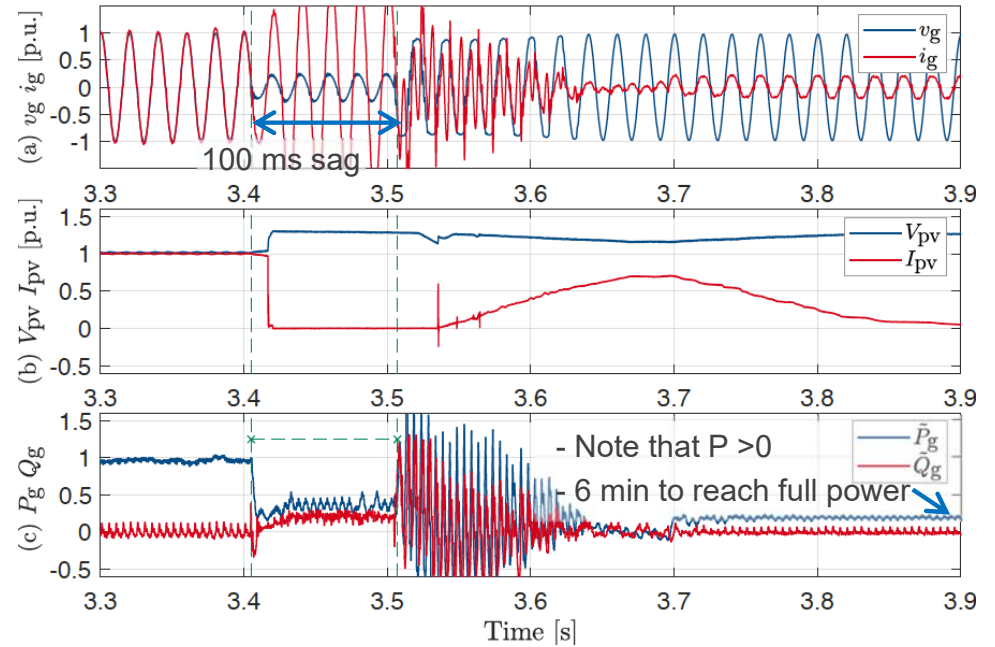

# Fast voltage sag curtailment to 0 W

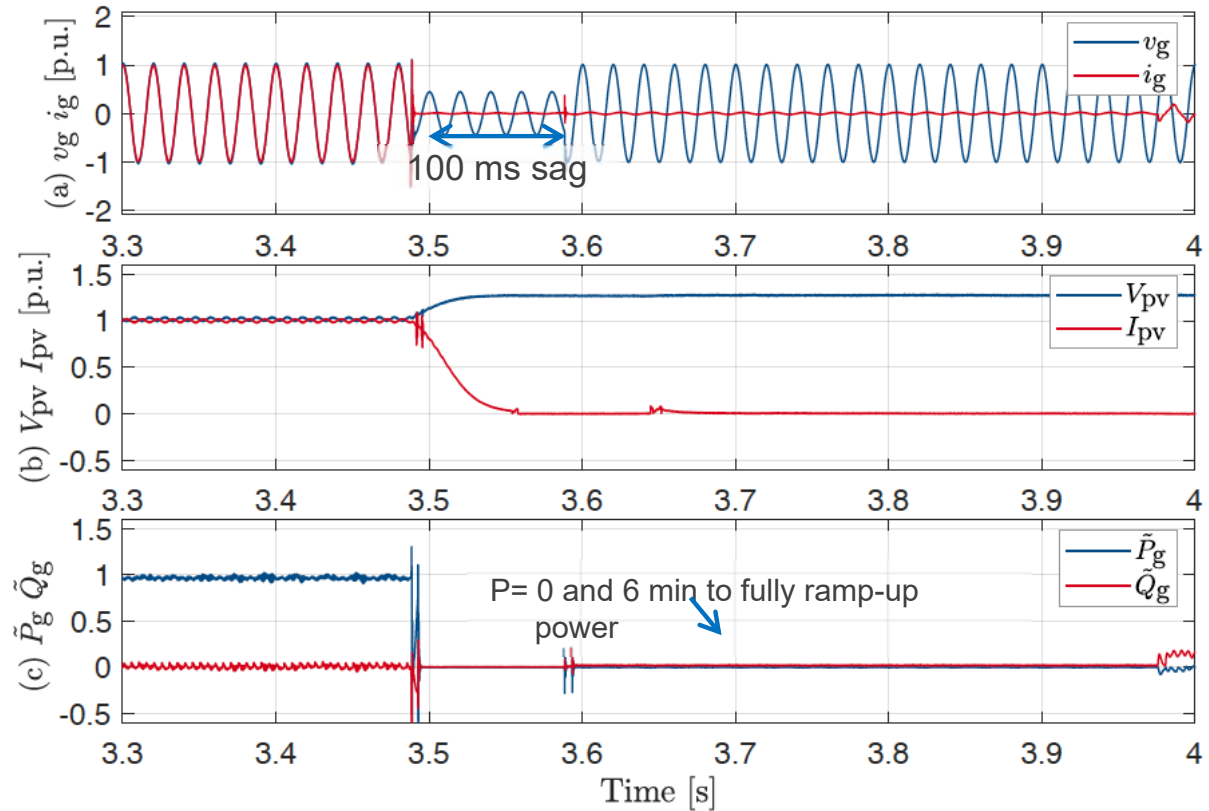



# Phase angle jump test

Phase angle profile applied:

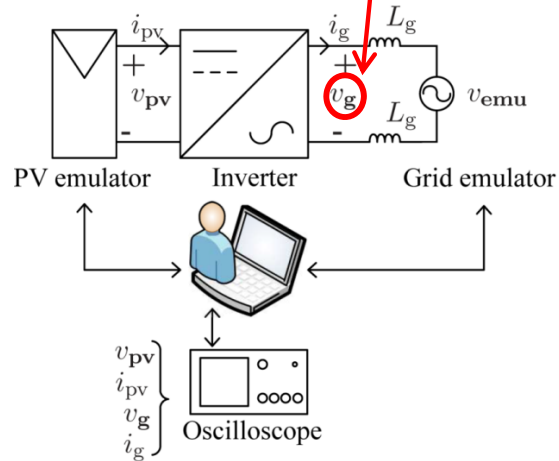
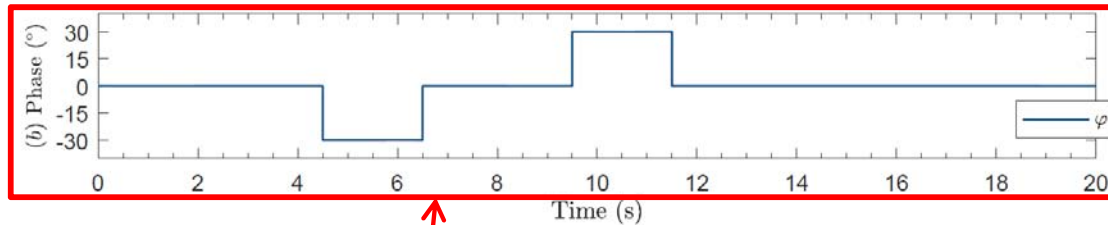

Possible inverter behaviour:

- Ride-through
- Power curtailment
- Disconnection

# 15° phase angle jump ride-through

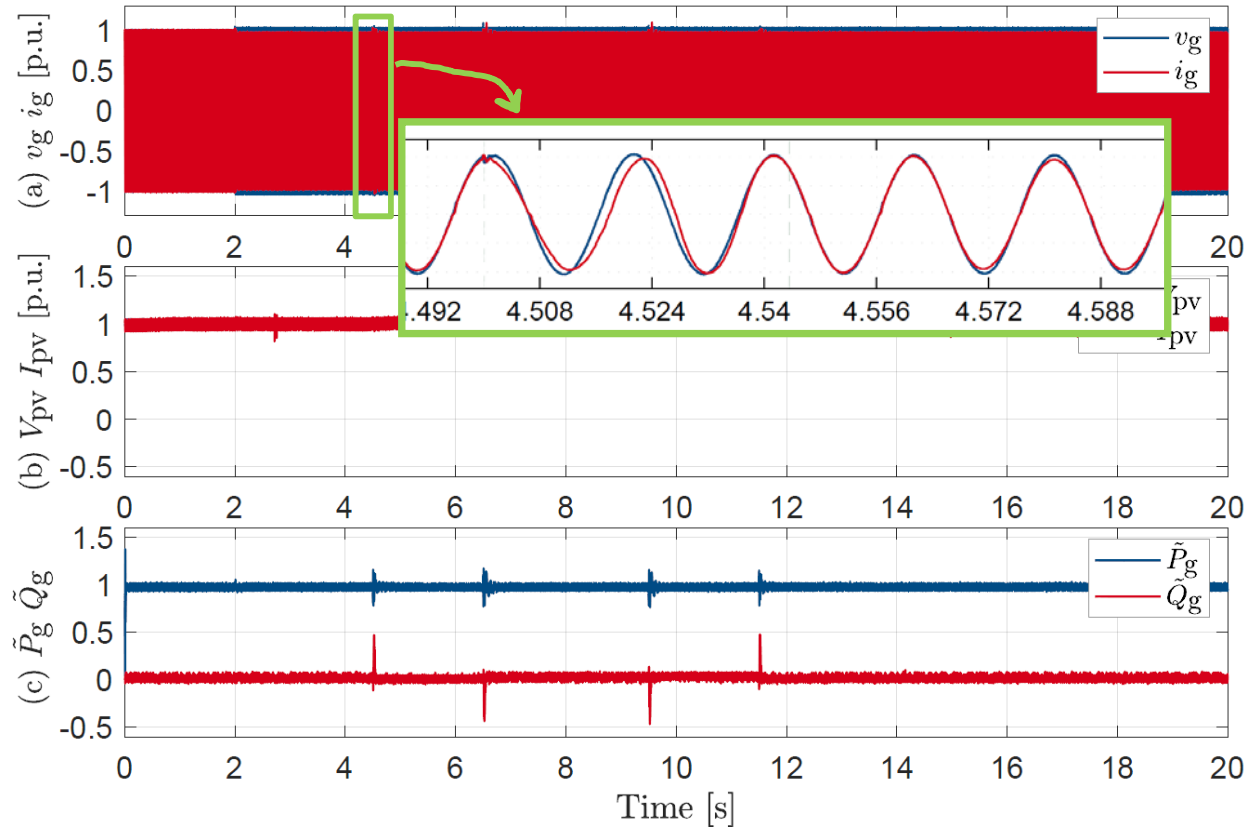

# 30° phase angle jump disconnection

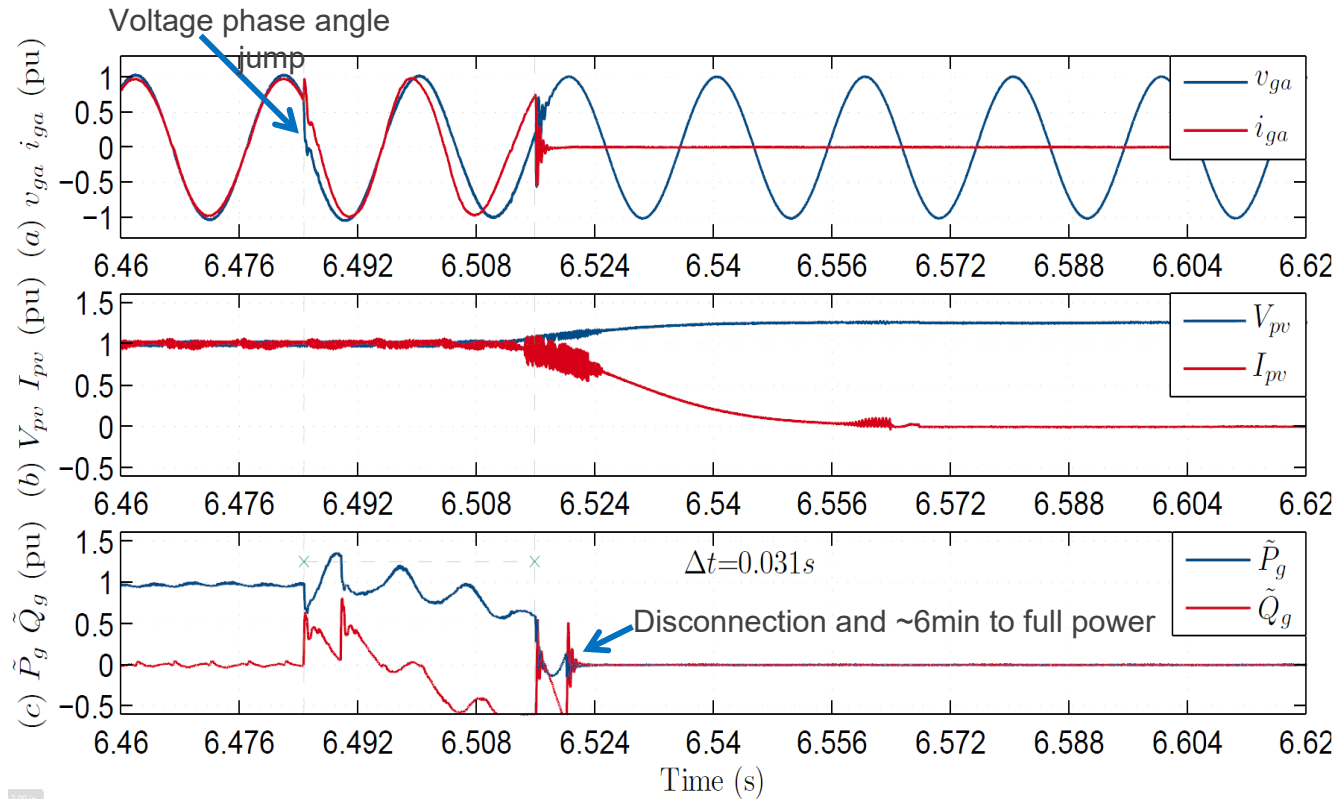

# 30° phase angle jump power curtailment

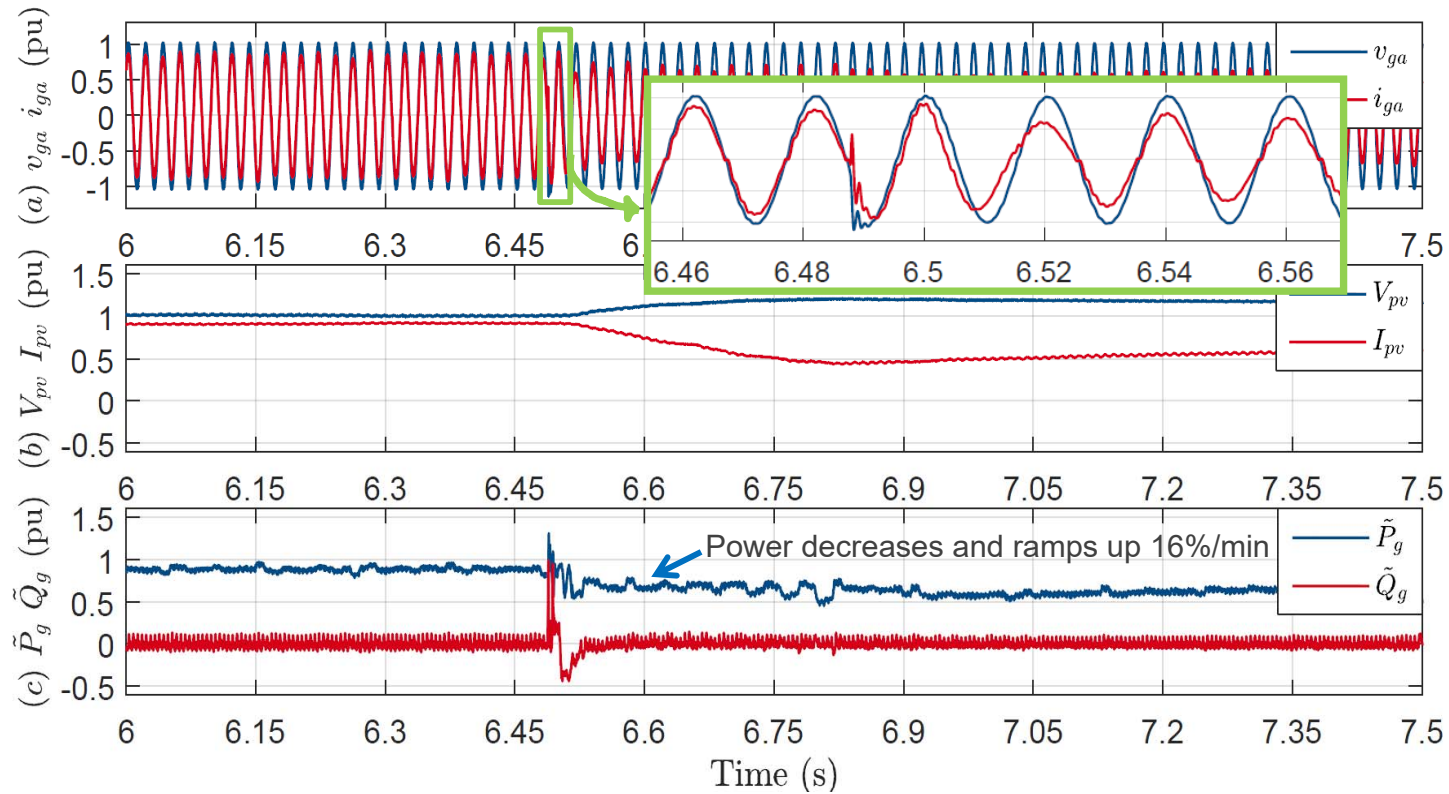

# Rate of Change of Frequency (RoCoF) test

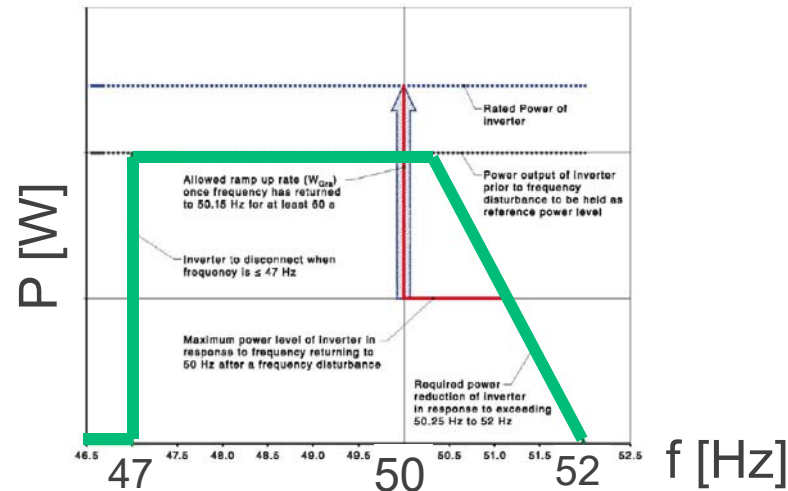
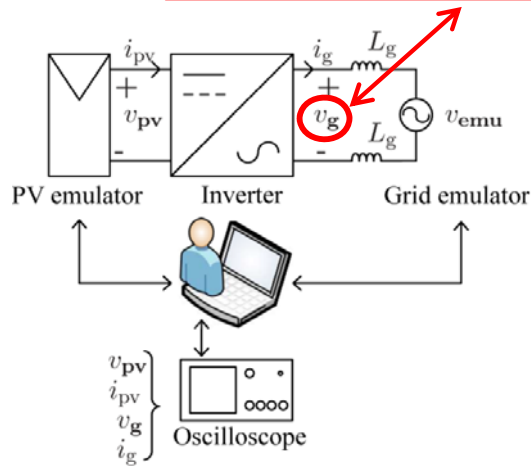
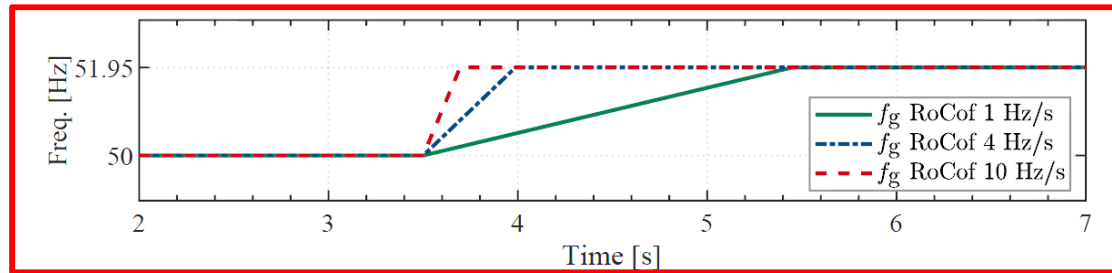

Possible inverter behaviour:

- Ride-through (frequency-Watt response)
- Disconnection



# 1 Hz/s RoCoF

Ride-through or disconnection?

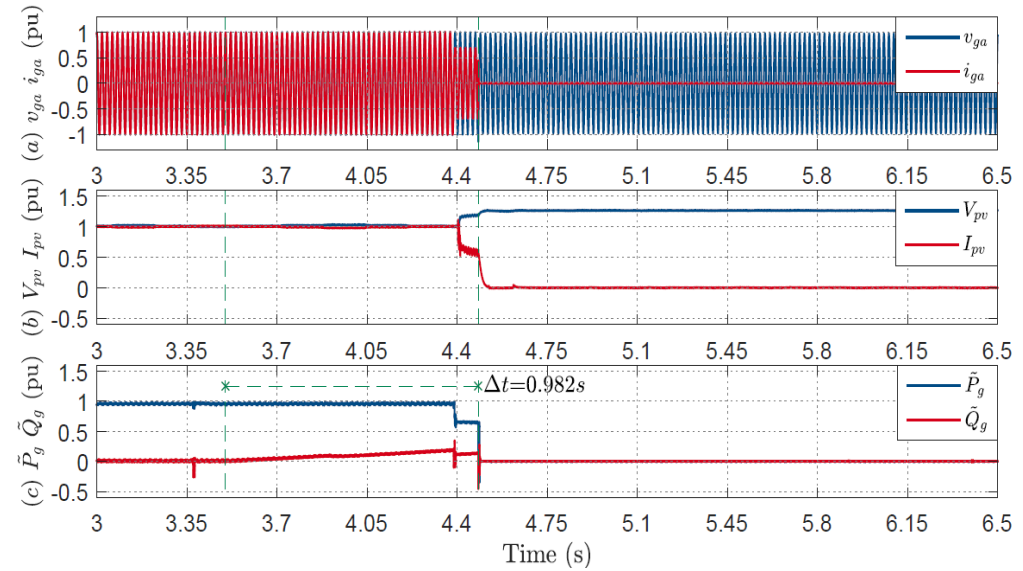
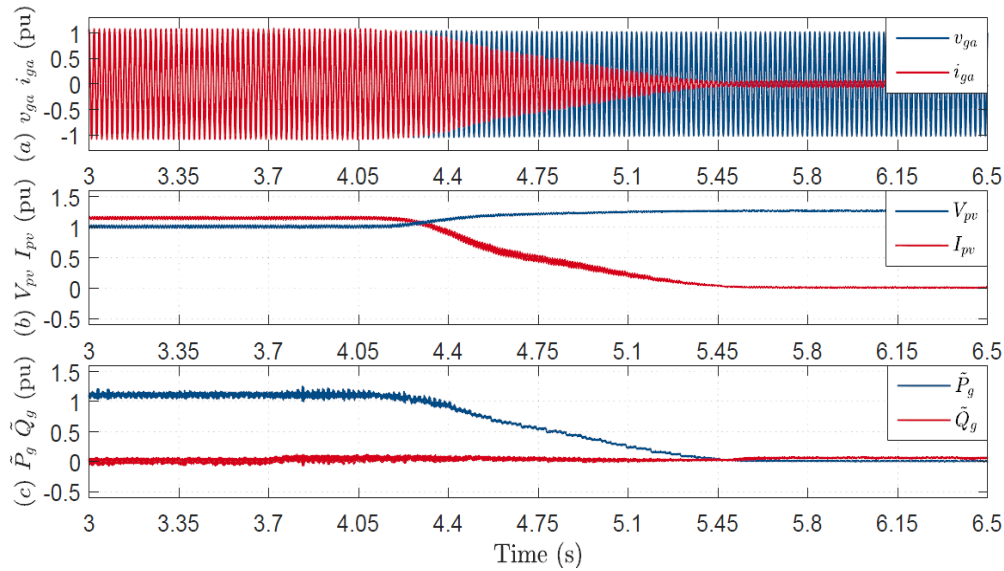

# Summary

Potential loss of PV power caused by grid disturbances

	Fast voltage sag	45° phase jump	1 Hz/s RoCoF
Inverter tested disconnecting or curtailing	30%	55%	17%
DER power affected*	2 – 30%	3 – 29%	3 – 39%

\*percentage out of total DER power installed in Australia from PV systems up to 9.5 kW

<http://pvinverters.ee.unsw.edu.au>



**UNSW**  
SYDNEY

Australia's  
Global  
University

# Real-Time Simulations





# Standards Testing vs Field Experience



# Can RTS Enhance Standards Validation

## Standards Compliance

- Pass / No Pass
- Specific conditions
- “Unrealistic” scenarios
  - e.g. frequency response for AS4777.2 (2015): slow reduction to 47.1 Hz then outside of range
- Single Inverter tests
- No network considerations

## Power Hardware-in-the-loop

- Functional testing based on network models
- Upstream / Downstream faults
- Integrated transmission and distribution cases
- Multiple Inverters in a distribution system
- Unbalanced networks



# Current Bench Test

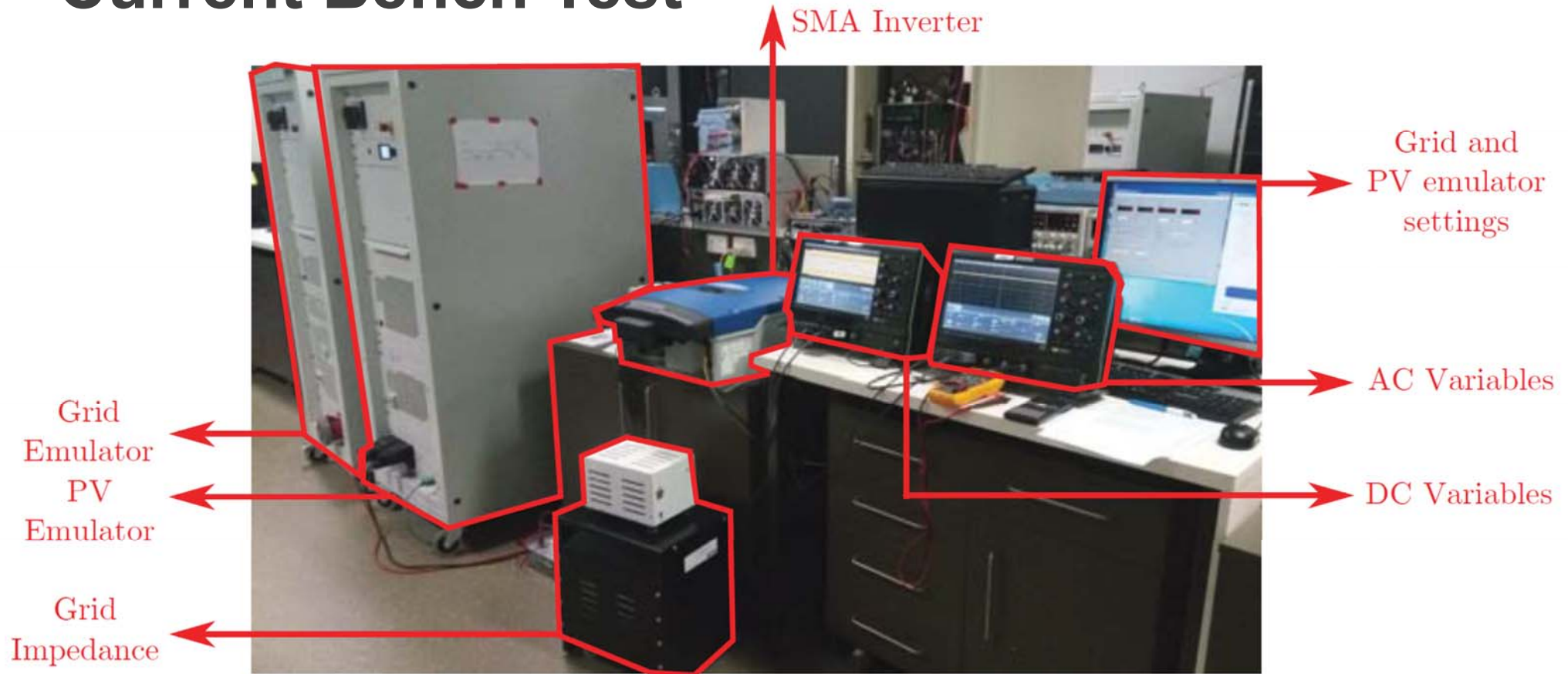

# Benefits of PHiL for Inverter Testing

Next step:

Performance validation through Power Hardware-in-the-Loop (PHiL).

- Test at different levels of solar PV penetrations in feeders.
- Coordinate testing of multiple inverters in the same feeder.
- Test for multiple feeders (urban, suburban, rural etc)



# Stage 2 Bench Testing

## Preliminary Steps

- Based on RSCAD v5 **Distribution Mode**
- Using IEEE benchmark models of distribution networks (e.g. IEEE 34 bus)
- Development of test procedure
- Validation against existing bench testing results
- Impact of location – Worst case scenarios
- Testing automation

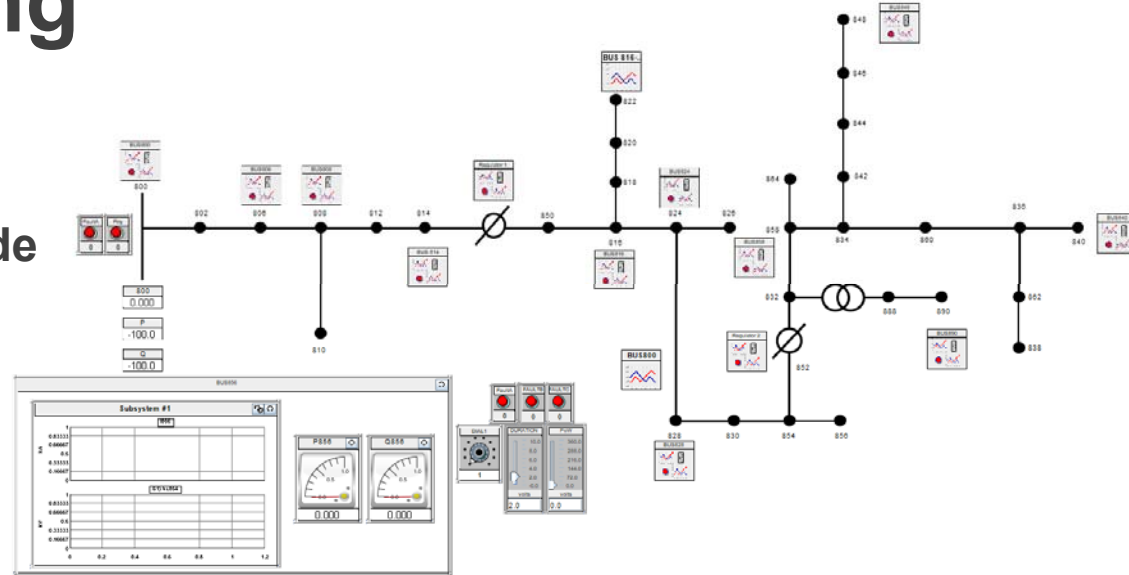

# Stage 2 Bench Testing

## Next Steps

Development of real-time models for Australian distribution networks

- Medium voltage networks
- Low voltage networks
  - e.g. ARENA supported projects
- Extension to multiple inverters on the same distribution network
- Hybrid Power HiL / simulated inverters

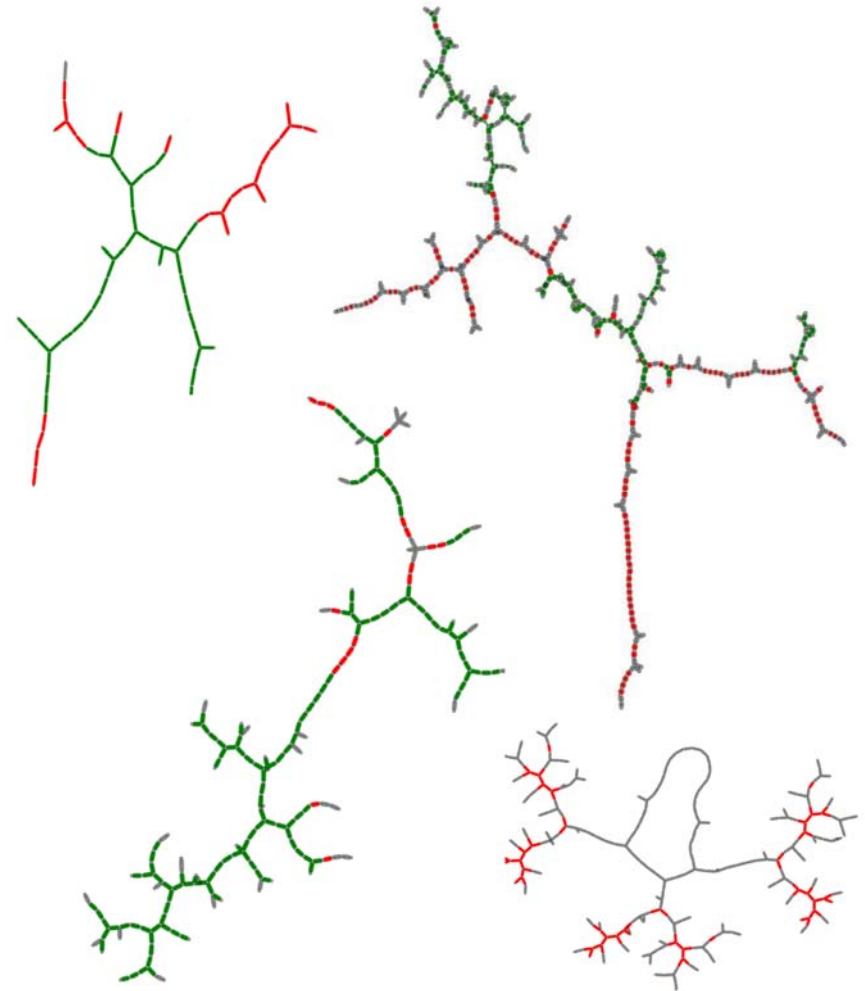

# Stage 2 Bench Testing

## Next Steps

- Integration of transmission and distribution networks
  - Currently at offline (PSCAD) stage

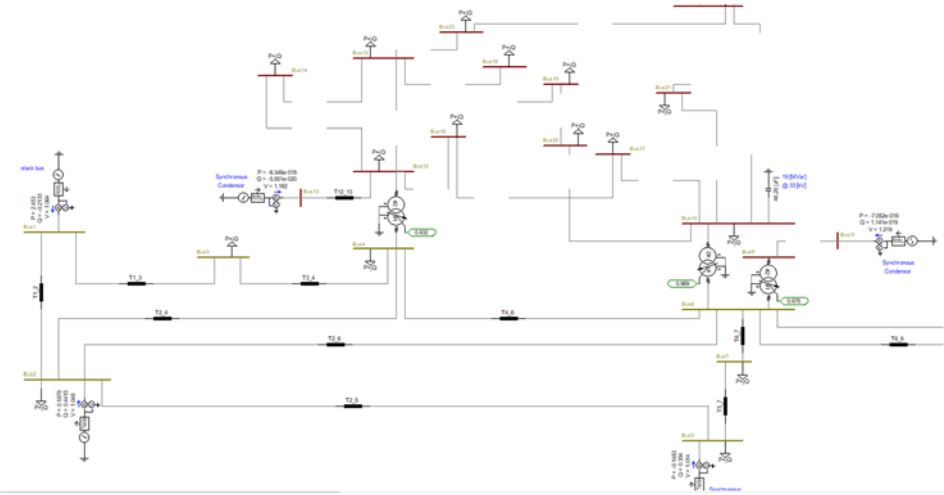

Multiple Run	Time	Fault Resistance	Type	Location	Pre Fault Voltage	Phase A Voltage	Phase Angle A	Sag %age	Phase B Voltage	Phase Angle B	Sag %age	Phase C Voltage	Phase Angle C	Sag %age
1	0.51204719	1	SLG	TBus6	0.205	0.13304338	-51.96423	35.101%	0.18155702	173.22177	11.436%	0.12889746	40.29460	37.123%
2	0.503693369	10	SLG	TBus6	0.205	0.13292607	-54.17001	35.158%	0.18152769	173.20063	11.450%	0.13393267	40.10583	34.667%
3	0.517627293	1	LLG	TBus6	0.205	0.05917304	-50.24133	71.135%	0.14160664	-168.86007	30.924%	0.12460708	35.77649	39.216%
4	0.511507275	10	LLG	TBus6	0.205	0.06361323	-60.75183	68.969%	0.13905912	-171.01345	32.166%	0.13136700	36.00503	35.919%
5	0.505114479	1	3 Phase to Ground	TBus6	0.205	0.05894992	-50.45326	71.244%	0.05924292	-171.17646	71.101%	0.05845027	68.93553	71.488%
6	0.508952569	10	3 Phase to Ground	TBus6	0.205	0.06347379	-60.97862	69.037%	0.06379110	178.29780	68.882%	0.06293606	58.40843	69.299%
7	0.500997315	1	SLG	TBus8	0.205	0.14530420	-53.99529	29.120%	0.18168642	173.10895	11.372%	0.13484950	45.23764	34.220%
8	0.502443654	10	SLG	TBus8	0.205	0.14451278	-55.82698	29.506%	0.18166174	173.09480	11.385%	0.13922969	44.57766	32.083%
9	0.501973768	1	LLG	TBus8	0.205	0.08647313	-53.87036	57.818%	0.14971139	-172.41533	26.970%	0.13235835	42.60810	35.435%
10	0.518076402	10	LLG	TBus8	0.205	0.08974365	-60.33905	56.223%	0.14740652	-174.28799	28.094%	0.13799633	42.17809	32.685%
11	0.514044755	1	3 Phase to Ground	TBus8	0.205	0.08629762	-54.02879	57.904%	0.08673540	-174.74722	57.690%	0.08557644	65.35717	58.255%
12	0.506396256	10	3 Phase to Ground	TBus8	0.205	0.08963115	-60.49951	56.277%	0.09008675	178.78162	56.059%	0.08888197	58.88572	56.643%
13	0.509426819	1	SLG	DBus806	0.205	0.12171954	-55.46713	40.625%	0.18274354	172.91091	10.857%	0.13660978	34.67503	33.361%
14	0.513279956	10	SLG	DBus806	0.205	0.17857772	-64.31219	12.889%	0.20144729	176.03293	1.733%	0.19202801	49.95069	6.328%
15	0.505424751	1	LLG	DBus806	0.205	0.06210361	-101.87509	69.706%	0.11234189	-171.80261	45.199%	0.14583081	31.77511	28.863%
16	0.502997877	10	LLG	DBus806	0.205	0.15818311	-74.68454	22.838%	0.16241840	171.62308	20.772%	0.17536906	47.31086	14.454%
17	0.50722809	1	3 Phase to Ground	DBus806	0.205	0.06250178	-102.28187	69.511%	0.06169565	135.35600	69.905%	0.05987278	17.21269	70.794%
18	0.504870888	10	3 Phase to Ground	DBus806	0.205	0.15776516	-74.84313	23.041%	0.15846627	163.93849	22.699%	0.15519648	44.32183	24.294%
19	0.507611981	1	SLG	DBus828	0.205	0.15195600	-44.07241	25.875%	0.21098947	178.95061	-2.922%	0.14397410	45.01381	29.769%
20	0.514533109	10	SLG	DBus828	0.205	0.15265891	-49.75970	25.532%	0.21104366	179.11122	-2.948%	0.15956554	45.21661	22.163%
21	0.510534797	1	LLG	DBus828	0.205	0.03267067	-79.05333	84.063%	0.14102967	-156.17886	31.205%	0.15169050	35.94124	26.005%
22	0.504087777	10	LLG	DBus828	0.205	0.07451954	-83.22033	63.649%	0.14073233	-165.56070	31.350%	0.16779305	40.55279	18.150%
23	0.510560748	1	3 Phase to Ground	DBus828	0.205	0.03114022	-80.97170	84.810%	0.03034457	157.88236	85.198%	0.03021661	39.76915	85.260%
24	0.512409169	10	3 Phase to Ground	DBus828	0.205	0.07297808	-84.55832	64.401%	0.07125090	152.85914	65.243%	0.06929814	35.40296	66.196%

# Regatron Top.Con TC.ACS

□ **Amplifier operation mode** External signals are given on the analogue interfaces for each phase.

Any device which creates electrical signals, can be used as signal generator (in our case an RTDS GTA0 card).

Generally a good quality digital-/analogue interface with a minimum of three channels (one channel for each phase) is recommended.

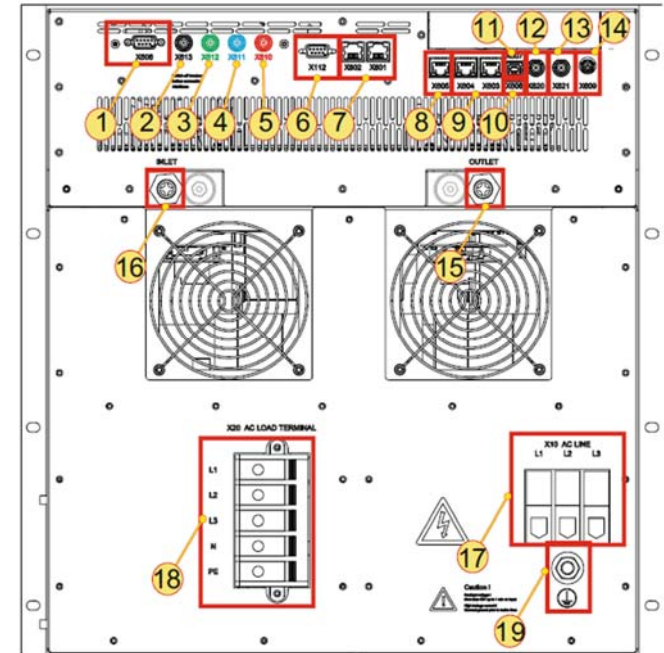
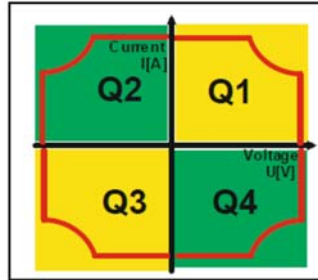

Fig. 5 Overview of interfaces - rear side



# Regatron Top.Con TC.ACS



**Feeding mode**  
positive power  
in Q1 and Q3

**Regenerative mode**  
negative power  
in Q2 and Q4



## 11.4.1. AC connection line side

AC connection line side	
Line voltage	3 x 380 – 440 V <sub>AC</sub>
Line frequency	48 – 62 Hz
Connection type	3 L + PE (no neutral)
Input current	3 x 85 Arms
Power factor	(0) – 1 at nominal power (default)

Tab. 23 AC connection line side – parameters.

## 11.4.2. AC connection load side

AC connection load side	
Power range	0 – 50 kVA
Voltage range	0 – 280 V <sub>rms</sub> (L-N)
Frequency range	Fundamental waves: 0 – 1000 Hz Full power: 16 – 1000 Hz
Connection type	3 L + N + PE
Current range	3 x 0 – 72 A

Tab. 24 AC connection load side – parameters.

# Regatron Top.Con TC.ACS

## 1) Output voltage versus frequency

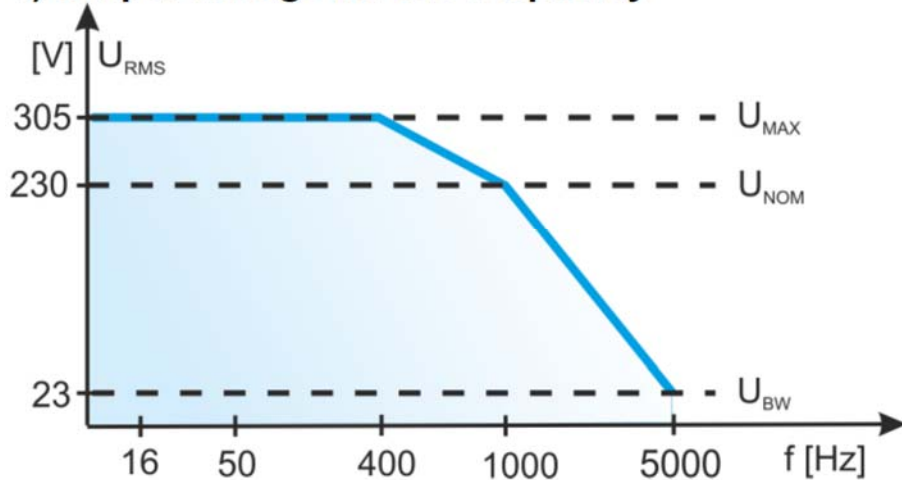

## 4) Slew rate at a resistive load

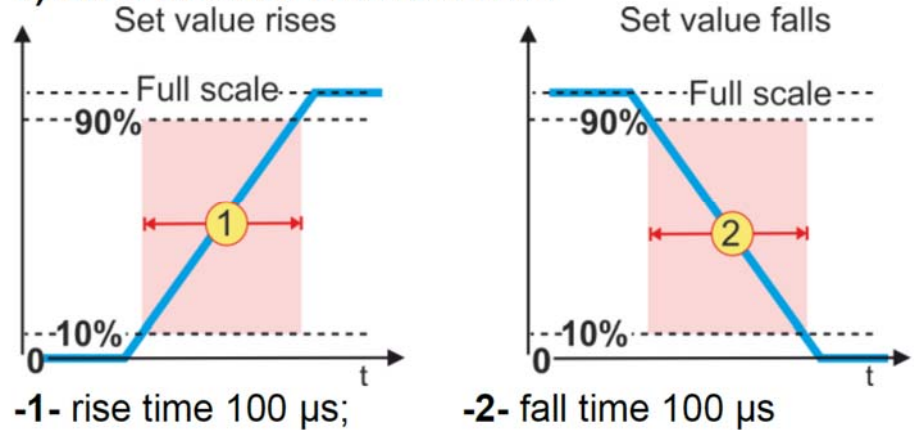

# Regatron Top.Con TC.ACS

## 2) Overloadability versus frequency

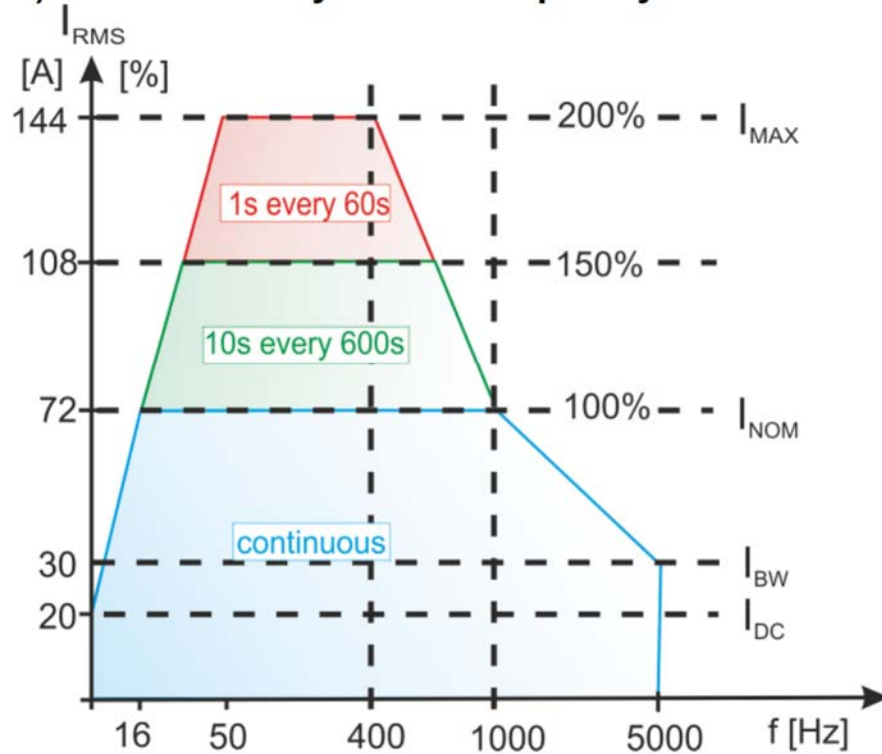

Typical Inverters at 5-10 kVA, within continuous operation of the system.

# Moving Forward

- Testing Automation
  - Current “power ramp rate” means **a lot** (really a lot) of waiting!
- Closed loop Power HiL simulation
  - Not critical to the test plan, but good to have!
- Generic Inverter models for real-time simulation
  - How to do that with multiple inverters?
- “Mission profiling”



# Summary



UNSW  
SYDNEY



Supplementing AS4777 Inverter compliance through Power Hardware-in-the-loop testing:

- Considerations for distribution feeders and transmission networks.
- Testing for different PV / RE penetration levels:
  - In a feeder
  - Across the network
- Validation against multiple faults (e.g. credible network faults and random events)
- Multiple inverters on the feeder (physical and simulated)
- Testing automation

# THANK YOU