

EXPERIENCES WITH DETAILED HARDWARE-IN-LOOP TESTING OF PROTECTION RELAYS AND SETTINGS WITHIN ESKOM

B Rigby^{*†}, A Perera[#], A Mtshali[#], S Klein[#], A Bartylak[#]
etalumiSe (Pty) Ltd^{*} Durban University of Technology[†] ESKOM[#]

ABSTRACT

This paper presents a review of how hardware-in-loop testing of protection relays on a real-time simulator has been put to use in a range of applications by Eskom. In some of these applications, models of relatively large parts of the transmission network have been used on a real-time simulator, either to study the performance of a relay already in service and improve its settings in response to changes in system conditions, or to test new protection settings and relay hardware prior to commissioning. In other cases, models of small-scale but representative study systems have been used to allow careful comparative evaluation of the suitability of different relay technologies for practical field conditions.

INTRODUCTION

For some years Eskom has helped to establish a specialist real-time simulator facility at a university in South Africa. As part of the research collaboration at this facility, the Real Time Power System Studies (RTPSS) Centre [1], detailed models of virtually all of the generation and transmission plant of South Africa's main grid (275 kV and above) have been developed for the real-time simulators, and the capacity of the simulators currently available allows significant sections of this transmission grid model to be run at any one time for particular studies. The real-time simulator, together with the aforementioned real-time models of Eskom's network, have proved to be an extremely useful tool for testing both protection relay settings, and protection relay hardware itself in a number of different applications. A companion paper to this one [2] describes the benefit of using real-time simulators to validate and certify models of protection relays used by Eskom in other, non-real-time EMT simulation tools. However in this paper, the focus is on discussing the benefits and experiences gained by Eskom from mainstream use of real-time simulators, that is to say for direct testing of actual protective relay equipment connected hardware-in-loop (HIL) with a detailed real-time simulator model of the protected plant.

Fig. 1 shows a conceptual overview of how HIL testing of relays on a real-time simulator is typically carried out. At the centre of the test facilities is a 19" rack that contains specialised, multi-processor computing and I/O hardware. A detailed EMT-type simulation model of the power system to be studied is developed on a separate personal computer host; this includes representations of all the relevant power system plant and components including instrument transformers, circuit breakers and

controllable faults. The model is then compiled and downloaded to run continuously, and in real time, on the RTDS simulator hardware (rack).

In the case of an impedance relay test, the instantaneous currents and voltages from the current and voltage transformers in the real-time model are sent to six channels of a high-precision analogue output card on the rack, converted to power-level secondary currents and voltages using a high-bandwidth amplifier, and injected into the appropriate measurement inputs of the relay. The trip outputs of the protection relay are then fed back into the real-time simulator via a digital input port on the rack and can be used to operate the poles of the circuit breaker in the real-time model. In this way, the relay under test is fed with instantaneous power-level inputs that respond continuously to whatever conditions and contingencies (faults, breaker operations etc.) are occurring in the on-going real-time simulation of the protected plant, and the relay's trip outputs affect the system it is connected to in the same manner as would be the case in the field.

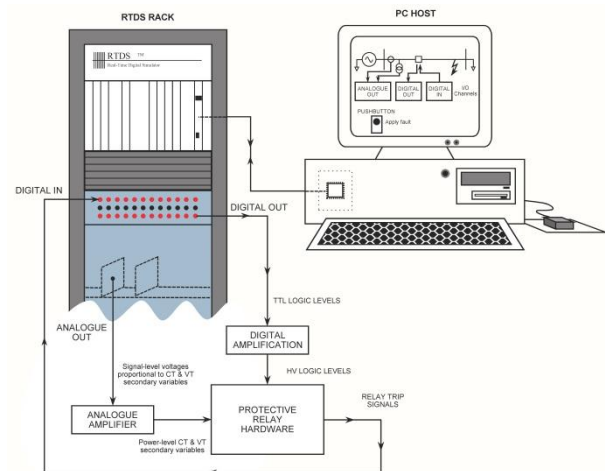

Fig. 1 – Hardware-in-loop testing of protection relays using a real-time digital simulator.

The diagram in Fig. 1 shows a single-rack real-time simulator in order to illustrate the basic principles of hardware-in-loop testing of protection relays. However, if the scale of the power system to be modelled on the simulator is larger than can be accommodated on the processors of a single simulator rack the real-time simulation can be spread over multiple such racks connected in parallel if such racks are available. With the continued addition of more simulator racks at the RTPSS Centre facility over several years, and with the improvement in the capability within these racks as

more-modern processor cards have become available during this time, it has become possible to simulate larger and larger parts of Eskom's transmission network for both protection and system stability studies. Indeed, the importance was recognised early on in the development of the RTPSS Centre of developing detailed real-time simulator models of Eskom's network so that wherever possible, when the need for specific studies in the area of protection investigations arose in the future, the real-time models of Eskom's system would be in place already.

However, depending on the particular type and focus of a hardware-in-loop protection relay investigation, the scope and level of detail that is actually needed in the real-time model of the protected plant can vary considerably. Hence, in order to explain both the different applications of HIL protection testing on a real-time simulator, and the different modelling approaches used in each case, this paper describes three different investigations that have actually been carried out by Eskom at the RTPSS Centre. These three examples have been chosen to illustrate some of the different categories of study that are possible using real-time models in the area of protection, the purpose of such studies, and the benefits to the utility obtained from conducting them. The chosen examples also illustrate the advantages of having a model of the entire network already developed for the real-time simulator. Depending on the nature and requirements of a particular investigation, additional modelling detail can then be added to a selected region within this larger model, or smaller-scale study system models can be developed specially for the investigation, but using component models (e.g. lines and transformers) taken from the full system model to ensure the representativeness of the study. Hence, before discussing the example investigations themselves, the paper starts by reviewing the real-time model of the Eskom transmission network that has been developed.

REAL-TIME MODEL OF ESKOM MTS

At the time of writing this paper, the real-time simulator facilities at the RTPSS Centre comprised 10 RTDS Technologies simulator racks. The size and scope of electrical power system that can be accommodated on such a 10-rack simulator depends on the level of detail required within the models of specific components, and on the extent to which parts of the network can be represented using simplified, lumped-equivalent models. However, early on in the establishment of the RTPSS Centre, a decision was taken to develop, over an extended period of time, a model of the whole Eskom transmission system that faithfully reflects the full topological detail of all its interconnected lines, at least at transmission voltage level. The development of this model has been carried out without consideration for whether there were enough simulator racks available at the time to accommodate the entire model, or even whether enough racks would be available at some point

in the future. Instead, the philosophy has been that with a full model developed and available, it would then be possible to have a real-time model of any significant subsection of the network in place, at least at a base level, whenever the need arose for studies in a particular part of the system in future.

However, despite having adopted this approach it has still been necessary to make use of some simplifications when developing the base model of the entire Eskom network, simply because of the practicalities of modelling large systems on a real-time simulator. In order to understand the background to some of the main simplifying assumptions needed when developing this large-scale real-time model it is necessary to explain some important principles associated with the process of accommodating real-time models on the processor hardware of a real-time simulator. Firstly, the real-time simulation algorithm (solution method) has to calculate the voltages at every electrical node that is explicitly defined in the system model, and there is a maximum number of these node voltages that can be solved on each individual rack in the simulator. Secondly, every item of electrical plant in the system that is modelled explicitly (with the exception of linear impedance branches) must have its mathematical model allocated to a particular processor on a rack for solution, and the processors on the rack can also only accommodate a finite number of component models. Lastly, adding further detail to the model of any particular component (e.g. opting to include saturation in a transformer model) uses up more of the finite processor resources on a rack than using a simpler (e.g. linear transformer) model.

Practically, these considerations mean that when developing large-scale electrical network models for real-time simulation, where the amount of available simulator hardware (both racks and processors) is always a limiting constraint, any modelling detail that introduces unnecessary electrical nodes (circuit breakers, underlying distribution networks, multiple line sections to represent non-homogenous transmission line types, etc.) is typically not included. Likewise, wherever there are multiple instances of the same type of plant connected in parallel in the actual electrical network (particularly generators and transformers) these are typically represented using a single component model whose parameters are chosen to represent all of the parallel plant lumped together. For the purposes of developing and maintaining a base real-time model of the Eskom system at transmission and generation level, this approach allows the largest possible size of system to be accommodated on any available simulator hardware. Then, when specific application studies are required, parts of this base model can be used, as needed, as a starting point and additional detail introduced to specific parts of the model as dictated by the demands of the particular study.

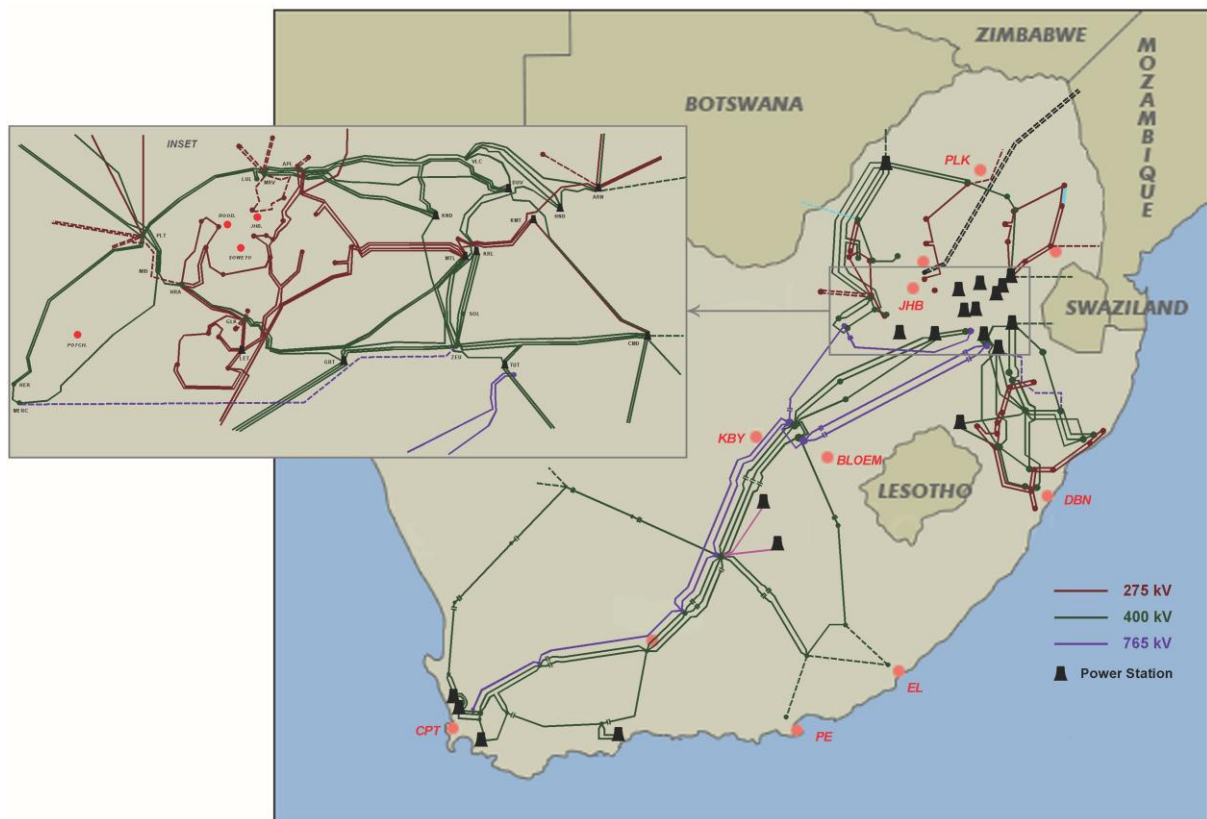

Fig. 2 – Geographical single-line diagram representation of the real-time simulator model of the Eskom main transmission system.

Using this approach, the real-time model of the entire Eskom transmission system has been developed over several years. Fig. 2 shows a geographical single-line diagram representation of this real-time model. This real-time model includes 26 power stations, each represented by means of a single, lumped, generator and step-up transformer model of rating equal to that of the station as a whole. Every transmission circuit at 275 kV and above is represented individually (i.e. without lumping of parallel lines) in the real-time model and each transmission-voltage static var compensator (SVC) in the system is included in a simplified form that allows the control action and variable Var output of the SVC to be represented without having to model its power electronic circuits. At all transmission substations in this base model the underlying distribution system is represented by means of a lumped PQ load model. All the shunt reactors and shunt capacitor banks in the transmission network are represented in the real-time model. Finally, every series capacitor bank in the transmission network is represented explicitly using linear capacitor component models.

This large-scale base model of the full Eskom transmission system would require approximately 20-25% more real-time simulator capacity than currently exists at the RTPSS Centre in order to run the whole model at once (although it would now be possible to accommodate this model on a somewhat smaller simulator using the latest generation of processor cards). However, it is possible to run significant sections of this network model on the RTPSS Centre simulators for

specific protection system studies, and in fact the entire system model has been developed as three stand-alone (and to some extent overlapping) sub-regional network models. The first of these sub-regional models to be developed for use on the real-time simulators was the Western Cape transmission network, driven by the interest in testing protection relay performance in the multitude of series compensated lines in this part of the system. However, over time this stand-alone model has been expanded to include the lines into the Eastern Cape as well as significant parts of the network north of Hydra, as will be discussed in more detail later. The second sub-regional model that was developed was that of the KwaZulu-Natal network. Finally, the model of the Northern and Central transmission systems was most recently developed for use on the real-time simulators.

As mentioned previously, the development of these real-time models was driven by the desire to be ready for any hardware-in-loop testing of specific protection schemes that might need to be carried out. Depending on the nature and focus of the particular protection relay tests to be carried out on the real-time simulators, one of these sub-regional networks could be used in its entirety, and additional modelling detail added where needed, or much smaller network models might be created using the parameterised component models from the base real-time model of the system as a whole. The following sections outline three particular investigations that have been carried out using these approaches.

OVERCURRENT RELAY STABILITY TESTS

Background

This particular series of tests that was carried out on the real-time simulators arose out of some problems reported from field experience with an older-generation overcurrent relay (referred to here as Relay M) used to protect switched capacitor banks on Eskom's network. It had been reported that this Relay M was susceptible to incorrect tripping during the transients caused when capacitor banks (either the protected bank itself, or other banks in the vicinity) are switched onto the network. This relay's poor stability in the presence of transient currents was thought to be as a result of the absence of any filtering circuits in its particular generation (electronic technology) of overcurrent relays. Although a newer, numerical-technology relay that does include filters (referred to here as Relay P) had already been identified by Eskom as a replacement to solve the problem of incorrect tripping during switching transients, it was considered important to formally verify the improved stability of the chosen replacement relay via hardware-in-loop real-time simulator testing. Using this HIL testing it would be possible, without risk to any actual system plant, to recreate switching transients that actually provoke the reported shortcomings of the older-technology Relay M, and then to confirm the ability of the new, numerical Relay P to discriminate and refrain from tripping in response to these same transients.

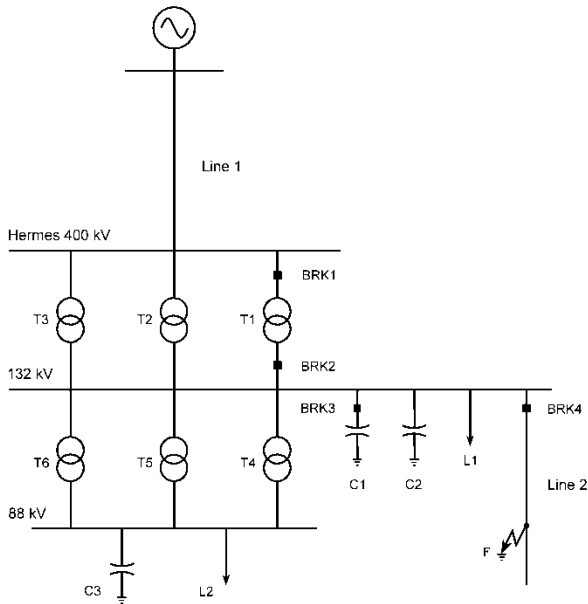

Fig. 3 – Single-line diagram of the real-time model used for testing shunt capacitor overcurrent relays.

A single-line diagram of the study system used for the tests is shown in Fig. 3. The system is based on the transformers and shunt capacitors at the Hermes substation, which was chosen as a representative example for testing purposes. The infeed to the Hermes substation was modelled via an ideal voltage behind constant source impedance, connected through a 100km

length of transmission line (Line 1) to the 400kV busbar.

Three transformers (T1, T2 and T3), each rated 400/132 kV and 500 MVA, connect the 400 kV and 132 kV busbars at Hermes in the real-time simulation model. In addition, controllable circuit breakers were included on the 400 kV and 132 kV sides of transformer T1 in the real-time model so that energisation transients caused by the switching in of this transformer could be studied. The real-time model included two 72 MVar shunt capacitor banks (C1 and C2) and a three phase load L1. The real-time model included a short length (52.35 km) of transmission line (Line 2) fed from the Hermes 132 kV busbar, with a controllable circuit breaker at the substation end, and a controllable short-circuit fault component that could be placed at various locations along the line. These details were included in order to allow replication of transients caused by faults, and subsequent fault clearing, on a nearby line. The real-time model also included three transformers (T4, T5 and T6) connecting the 132 kV and 88 kV busbars at the Hermes substation. A 48 MVar shunt capacitor bank C3 and a three-phase load L2 were modelled at the 88 kV busbars in the real-time model.

Of interest in this particular investigation is that the real-time simulation models of all six transformers in the study system were configured so as to include the effects of magnetic saturation in their cores. Although this added to the number of processors required to accommodate the model on the simulator, in this case the study system was relatively small in scale and, even with the additional modelling detail needed to represent saturation on all the transformers, it could still comfortably be accommodated on a single simulator rack. In this study, it was necessary to include transformer saturation specifically to allow the real-time model to be used to recreate the effects of non-linear transient inrush currents in the transformers on the rest of the plant in the system. The parameters of the two transmission lines in the system were based on representative lines of similar voltage and length in the actual Eskom network.

The specific focus of the study was to compare the responses of the two types of hardware overcurrent relays when each one was used to protect the shunt capacitor bank C1 on the Hermes 132 kV busbar in Fig. 3. Therefore, the real-time model included a current transformer (CT) in capacitor bank C1 and the secondary currents from this CT were exported from the real-time simulation via a digital to analogue conversion card for external amplification and simultaneous (series) connection to both of the two hardware relays (M and P) under test. The trip signals from the two hardware relays were read in from their respective output contacts, via a digital input port on the simulator, into binary variables within the real-time model for monitoring and capture. The real-time model also included specially-designed

control and logic circuitry to allow various switching events (opening and closing of capacitor and transformer circuit breakers, application and clearing of faults) to be applied at specified and repeatable points-on-wave of the voltages across the capacitor bank C1.

The two system disturbances that were considered in order to study the response of the overcurrent protection relays at capacitor bank C1 to transient currents were: energisation of one of the three 400/132kV transformers at Hermes; a fault on the 132 kV line emanating from the Hermes busbar, followed by clearing of the fault a short time later. Both of these are realistic contingencies that could give rise to transient currents in the shunt capacitor banks in practice.

Response To Energisation Of Transformer T1

In this test scenario the transformer T1 in the real-time model was energised by closing the breaker BRK1 on its 400 kV side, whilst the breaker BRK2 on its 132 kV side remained open. In all cases the breaker BRK1 was closed at the instant when the A-phase voltage across the shunt capacitor bank C1 was at an angle of 90 degrees (maximum A-phase to neutral capacitor voltage). This transformer energisation test was repeated several times under different load conditions using the real-time simulation model. A sample set of results from three such tests is shown in Figs. 4, 5 and 6.

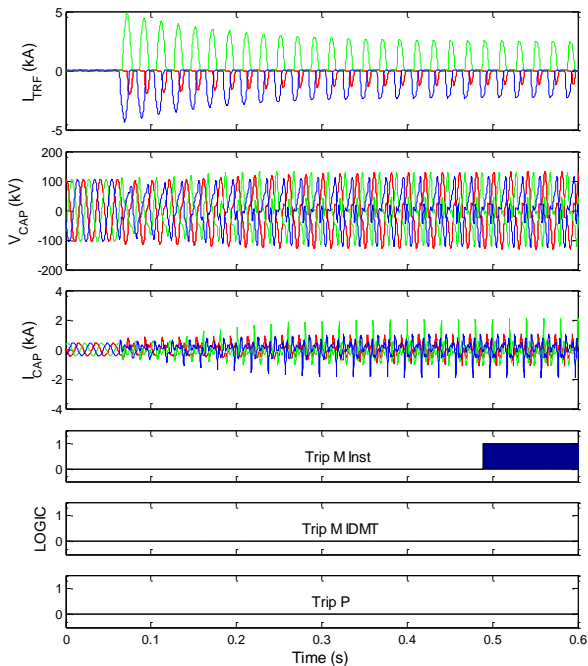

Fig. 4 – Response of two hardware O/C relays to energisation of transformer T1: Relay M trips (Inst.); Relay P stable.

In all three test results (Figs. 4, 5 and 6) the plots show that the transformer energisation results in poorly-damped second-harmonic current inrush into the transformer primary windings, and that this in turn causes transients in the capacitor voltages and currents. However, the results in Figs. 4, 5 and 6 also show that the specific characteristics of the transformer inrush

current transients, and hence in the capacitor bank current transients, are different for each transformer energisation test: this is not a result of different points-on-wave of the transformer energisation, since the point-on-wave of energisation was controlled to be the same in each of these tests. Rather, the transformer core's remanent flux in the real-time model was different in each test (exactly as it would be in practice in the field) based on the previous energisation history of the device, giving rise to different inrush current waveform characteristics each time the test is applied (again, exactly as would be the case in the field).

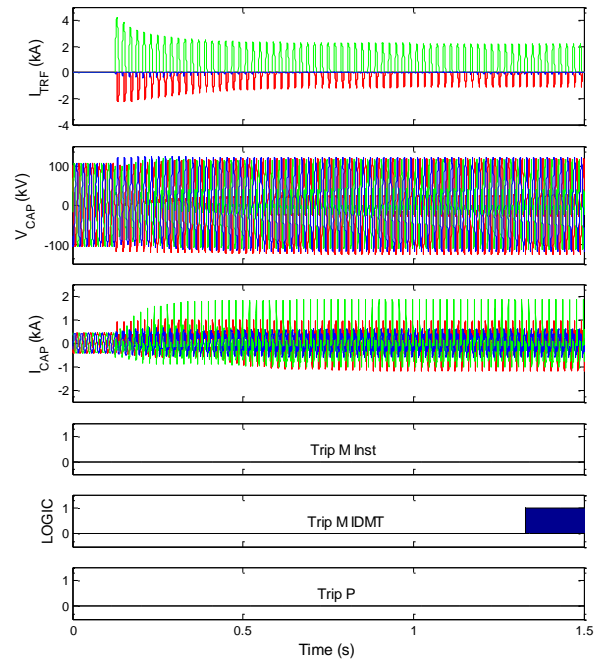

Fig. 5 – Response of two hardware O/C relays to energisation of transformer T1: Relay M trips (IDMT); Relay P stable.

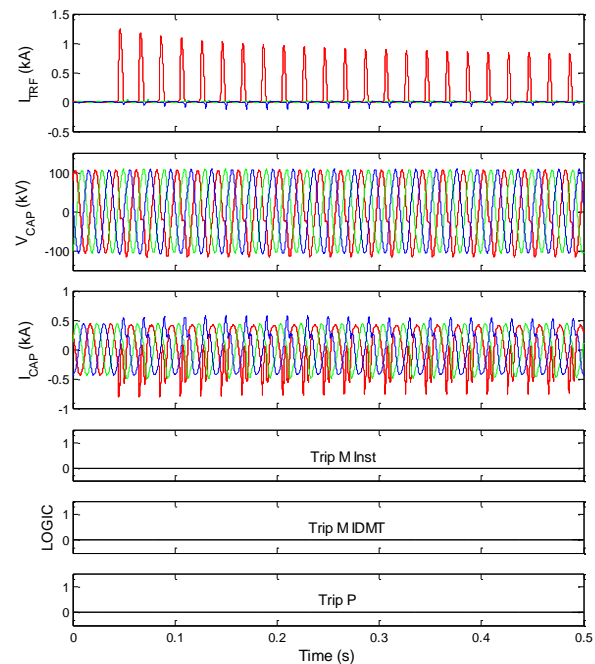

Fig. 6 – Response of two hardware O/C relays to energisation of transformer T1: Relay M stable; Relay P stable.

The results of repeated application of this transformer energisation test were able to confirm what was known from field experience, that the Relay M currently in use is susceptible to incorrect tripping in response to transient currents: the results in Fig. 4 show the Relay M tripping on instantaneous overcurrent in response to one instance of the test; the results in Fig. 5 show the Relay M tripping on IDMT overcurrent in response to another instance of the test; the results in Fig. 6 show the Relay M not tripping at all in response to a third instance of the test.

By contrast, the results in Figs. 4, 5 and 6 show that the Relay P (correctly) did not trip in response to the transients present in the capacitor currents for any of the repeated instances of the test.

Response To Faults And Fault Clearing On Line 2

In this test scenario different types of short-circuit faults were applied at locations along Line 2 in the real-time model, in each case followed 80ms later by clearing of the applied short-circuit fault by opening all three poles of the circuit breaker BRK4. In all cases the fault was applied at the positive-going zero crossing of the A-phase voltage across the shunt capacitor bank C1.

A sample set of results from two instances of one such test is shown in Figs. 7 and 8; in this particular test the fault considered was a single-phase to ground short circuit applied at the 132 kV busbar, cleared 80 ms later. The results in Fig. 7 demonstrate that in one instance of this test the Relay M's instantaneous element tripped as a result of the transient currents in the capacitors caused by the reappearance of the 132 kV busbar voltages after the single-phase fault is cleared, whereas Fig. 8 demonstrates that in another instance of the same test Relay M did not trip. The Relay P, by contrast, behaves correctly by not tripping in response to these transient currents in both instances of the test.

The results of these hardware-in-loop real-time simulator tests on different capacitor bank overcurrent protection relays illustrate one category of practical relay testing that has successfully been carried out using real-time simulators within Eskom. In this type of testing, the scale of the real-time model itself is relatively small (the simulation fits comfortably onto a single real-time simulator rack). However, because of the particular nature of the investigation, the level of detail in the models (in particular the representation of saturation in each of the transformers) is greater than might otherwise be necessary for larger-scale real-time models in other studies. Furthermore, in tests such as these, the models and the test regime are carefully designed to allow controlled and repeated testing of both of the hardware relays simultaneously using the same real-time model. In this way, it was possible to provide the necessary confidence in the proposed replacement relay hardware in two ways.

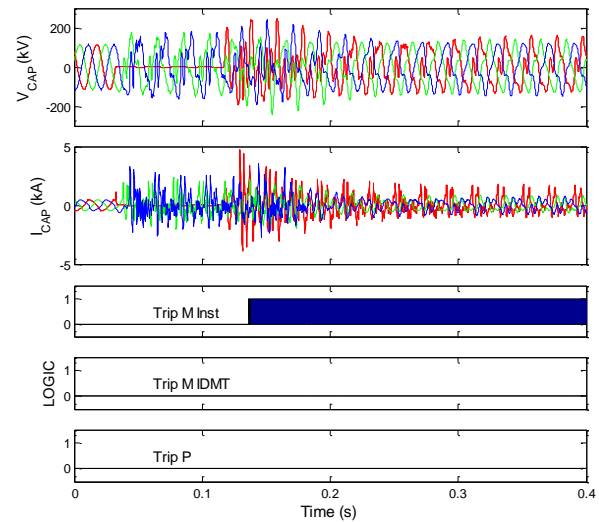

Fig. 7 – Response of two hardware O/C relays to a temporary fault at 132kV busbar: Relay M trips (Inst.); Relay P stable.

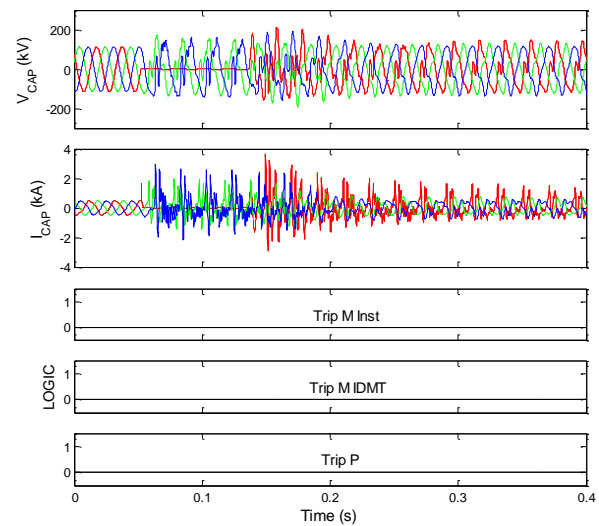

Fig. 8 – Response of two hardware O/C relays to a temporary fault at 132kV busbar: Relay M stable; Relay P stable.

Firstly, it was possible to definitively confirm the reported shortcomings of the relay currently in use. The real-time simulator tests were able to show that Relay M is indeed susceptible to incorrect tripping in response to transient currents in a manner that depends on the particular circumstances and operating conditions prevailing at the time of the switching event, exactly as would be expected to occur in practice for a relay reported to experience such shortcomings. This therefore provided confidence in the correctness of the modelling and testing regimen itself.

Secondly, the replacement Relay P (with no relaxation necessary in its settings from the standard overcurrent settings philosophy normally used within Eskom) did not exhibit a single incorrect trip in response to the same repeated transient tests (carried out in parallel with the tests on Relay M) over a range of different loads and operating conditions.

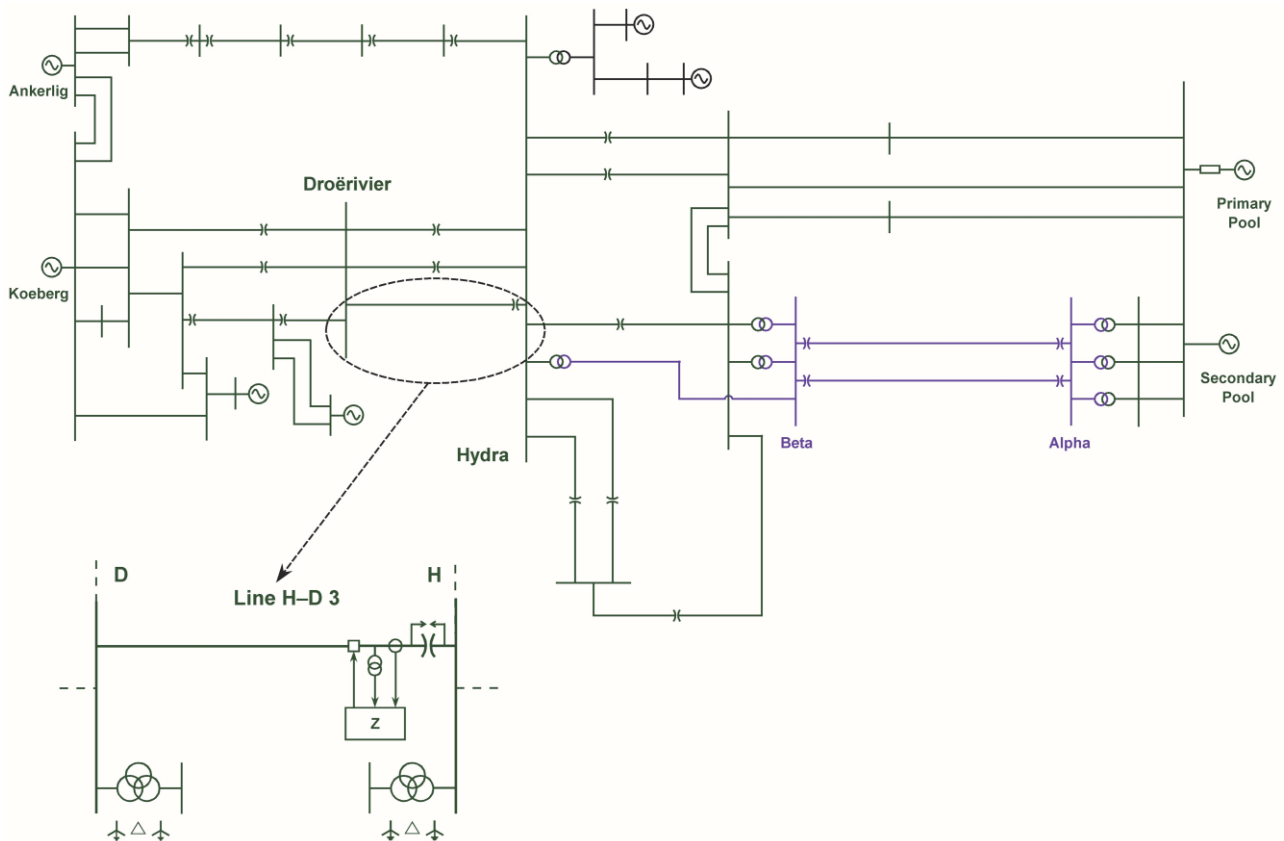

Fig. 9 – Single-line diagram of the real-time simulation model used for hardware-in-loop verification of an impedance relay's performance under current reversal conditions.

SETTINGS VERIFICATION OF AN IMPEDANCE PROTECTION RELAY FOR CURRENT REVERSAL CONDITIONS

The background to this test was an unexpected current reversal condition that was discovered during settings verification after the commissioning of a new series capacitor at Hydra substation; EMT simulation studies within Eskom had identified that the impedance relay at Hydra on the Hydra-Droërivier 3 Line would, as a result, not be able to establish correct directionality for close-up forward faults in certain system configurations. The intentions behind the real-time simulator testing in this case were twofold: to confirm that the actual hardware relay being used in the field would exhibit the problem that had been identified during EMT settings verification studies; to confirm the correctness of the settings approach being considered to solve the problem, again using the actual relay hardware.

This test is one example of where it was possible to take advantage of the previous efforts, over time, to develop a large-scale real-time model of Eskom's Western Cape transmission system at a base level, and to add specific detail into this model in the localised region of interest for the particular relay being tested. Fig. 9 shows a single-line diagram of the real-time simulator model of the Western Cape transmission system that was used for this set of tests. The real-time model of the grid represents all the generating stations and transmission

lines in the region, including explicit representation of series capacitors and transmission substation loads wherever these are present in the actual system. The detailed representation of the topology of the transmission network is retained well beyond the substation of interest in the tests (Hydra), with two large, lumped primary and secondary generating pools being used to represent the rest of the Eskom system beyond the 765kV station at Alpha.

This base level model of the Western Cape network used as the starting point in this study was developed to be able to represent the true electromechanical swing dynamics of the system, and the resonant effects due to series compensation in the network, as appropriate for a macro-level of study, but it (intentionally) does not include series capacitor protection (MOVs and/or spark gaps) at all locations, or detailed representation of equipment such as distribution transformers at each substation. However, the inset in Fig. 9 shows that for the purposes of the particular tests being conducted during this HIL study, additional detail was then added to the large-scale model in the localised area in which the protection relay was to be tested. Three-winding transformers of the correct vector group, earthing configuration and MVA rating were added at both the Droërivier and Hydra substations in the model in order to ensure the correct ground fault contributions from each end of the protected line. A custom model and

control logic was also added so as to correctly represent the dynamic action of the spark gap that protects the series capacitor in the Droërivier-Hydra 3 Line.

With the appropriate level of detail added to the real-time simulation model in the vicinity of the Droërivier-Hydra 3 Line, the actual protection relay was connected hardware-in-loop at the Hydra substation and a range of tests carried out. As a result of these tests, it was possible to confirm the current reversal condition and the inability of the hardware relay to establish directionality under the conditions in which this was expected. It was also possible to test the correctness of the proposed settings solution on the actual relay hardware in a detailed real-time model of the system: a simple high-set overcurrent function has since been deployed on this relay in order to cover for high-current, close-up faults in current reversal conditions. This particular investigation provides an excellent example of where the HIL testing on the real-time simulator was used by Eskom to test a relay that had been in service for some time in the field, and where the focus was on testing the behaviour of the relay, and some proposed new settings, at a single, specific location in the network in response to changed system conditions. With the assistance of these hardware-in-loop real-time simulator tests, it was possible to confirm and eliminate a weakness in the protection system, allowing for improved performance in cases of series capacitor bypass failure.

SETTINGS VERIFICATION FOR IMPEDANCE RELAYS ON ESKOM'S NEW 765 kV LINES

The most recent protection system tests that have been carried out on the real-time simulators provide another example in which a large-scale model of the transmission system was used for detailed hardware-in-loop relay testing. However, in this case the objective was to carry out tests on new impedance relay hardware and new settings that were due to be put in place on the 765 kV transmission lines that were in the final stages of commissioning by Eskom. Also, in this particular case, the HIL impedance relay tests were not focused on just one location in the transmission network; instead, the testing was to be carried out for relays located at both ends of each new 765 kV line being added to the actual grid (some eight different relay locations). Furthermore, during the technical preparation for the tests it was decided that because of the particular topology of the network in the area of interest, the real-time model to be used for these tests needed to include the most realistic representation possible of the interconnected network surrounding all the new 765 kV lines whose protection was to be tested. (This was the principal driver behind using such a large-scale network model for these particular real-time simulator tests.)

Fig. 10 shows a single-line diagram representation of the real-time simulation model that was used for this particular project. This model included the entire

Western and Eastern Cape transmission network models used for the previous tests just described in the paper (cf. Fig. 9) with some additional detail included to reflect upgrades that had been made on the actual 400kV network in this region since those earlier tests were carried out. However, the scope of this study also required more of the actual transmission network to the north of Hydra (to the right of Hydra in Figs. 9 and 10) to be included in the model: the detailed representation of the transmission network topology was therefore extended beyond the Pluto, Midas and Zeus busbars for this study as shown in Fig. 10. The additions to the real-time model for this study also included models of all the new 765 kV lines and substations already in existence or being commissioned, and the transformers interconnecting them with the existing 400 kV network, as well as representations of the 765 kV lines to be built in the future, including the envisaged 765/400 kV substations at Omega, Kappa and Gamma.

As with the previous study, all of the series capacitors in the real time model of Fig. 10 were represented explicitly, but in this case non-linear MOV protection had to be included in the models of the series capacitors in the vicinity of every relay being tested, which added considerably to the number of processors used on the simulators (this study system model required 5 of the 10 simulator racks at the RTPSS Centre). Furthermore, the series compensation at one particular location in the Eskom network (Beta) is, because of its large rating, made up of two discrete MOV-protected series capacitor banks connected in series, rather than a single bank. This level of detail was therefore also added to the real-time model of the Beta series capacitors for these particular HIL tests to allow the relays to be tested as thoroughly as possible (i.e. such that faults could be considered at locations in the middle, or on either side of the two discrete banks that actually make up the total series capacitance at the Beta substation in practice).

The type of impedance relay being used in Eskom's new transmission protection schemes was then connected hardware-in-loop to the real-time simulator and was used, in turn, to study the performance of the actual relay and its settings at both ends of four different 765kV lines in the real-time model of Eskom's transmission network in Fig. 10, namely: Mercury-Zeus; Mercury-Perseus; Beta-Perseus; Hydra-Perseus. The appropriate settings corresponding to each of these eight relay locations were entered into the hardware relay before each test, and a range of different faults applied both internally (on the protected line) and externally (on nearby lines and behind nearby series capacitor banks) for strong and weak network topologies.

The purpose of the tests was to obtain final confirmation of the thinking and settings calculations employed by Eskom's protection engineers for distance elements in the new-generation of relays to be used on these new 765 kV lines. The results of the tests did indeed provide

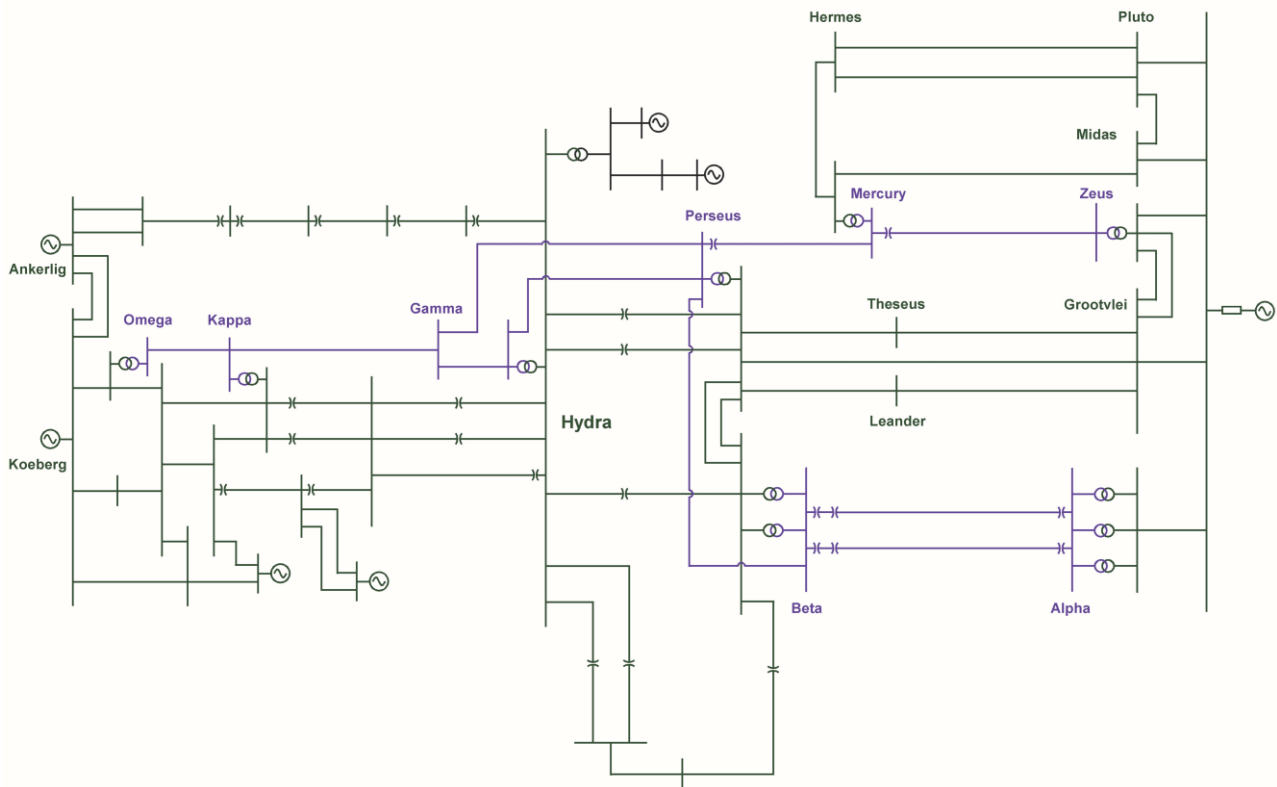

Fig. 10 – Single-line diagram of the real-time simulation model used for hardware-in-loop confirmation of impedance relay settings for new 765 kV lines.

confirmation of both the settings philosophy and calculations used for these distance elements. However, as a further benefit of being able to carry out such detailed tests using the actual relay hardware on a real-time simulator, Eskom’s protection engineers were able to discover some errors in other, supplementary settings in the relays, gain insight into the likely effects of these errors, and find solutions or corrections as required. Examples of the issues identified can be summarised as follows:

- An error was identified in the phase selector settings. The consequence of this error would have been a three-pole trip on the actual system in cases when the relay should instead trip single-pole.
- A time setting was found have too small a value on one particular timer on the relay. The consequence of this inappropriate setting would have been a single-pole trip, followed 120 milliseconds later by a 3-pole trip.
- The zero-sequence voltage setting for detecting high-resistance earth faults was found to have been set too high. The consequence of this inappropriate setting would have been that the relays in the field would not have detected high-resistance earth faults.

In general however, the hardware-in-loop real-time simulator tests verified that the thinking behind the impedance settings for the 765 kV line protection is

correct, particularly in respect of the security of these protection settings in the presence of series capacitors elsewhere in the network.

CONCLUSION

This paper has presented an overview of three different hardware-in-loop relay testing projects to illustrate the different ways in which real-time simulators have been put to use by Eskom in the area of protection systems. The paper has outlined a real-time model that has been developed of Eskom’s main transmission system, at a macro-level of modelling detail, and shown how this model can be used as the basis for carrying out specific hardware-in-loop relay investigations as a valuable part of the protection settings and optimisation process within the utility.

The paper has demonstrated how, for some applications, a model of relatively large areas of the grid represented at a macro-level such as that described, together with added localised modelling detail in the particular area of interest has been found to be an effective strategy for using a real-time simulator in studies to recreate particular field events and conditions, and thereby to improve the settings of existing relays in the field.

In other applications this same approach has been found useful to allow thorough analysis of new settings philosophies and new relay hardware on a simulator, using real-time models that closely represent the

topology of the interconnected network surrounding the relays, before these relays and their settings are put onto the system. It has also been shown that real-time simulator testing of the actual relay hardware using such realistic network models and scenarios not only allows protection engineers to verify the thinking behind the settings philosophy of the fundamental components (such as distance elements) within a protection scheme, but also greatly assists them in uncovering, and fixing, errors in the significant number of monitoring, timing and other supplementary elements that are present in a modern numerical protection relay.

Finally the paper has shown that, by contrast, for some protection relay test studies, relatively small-scale, but detailed real-time models are sufficient to recreate the specific types of power system transients needed for hardware-in-loop testing. The paper has shown a particular example of this type of test application in which the real-time simulators were able to provide a powerful platform for careful comparative testing of two different relay technologies and, in so doing, confirm the suitability of the new-technology relay for solving a known operating problem being experienced in the field.

REFERENCES

- [1] Rigby B S: "The Real-Time Power System Studies Centre: A Facility For Enhanced Teaching And Research In Power Engineering", Proceedings of the 13th Southern African Universities Power Engineering Conference SAUPEC '04, Stellenbosch, South Africa, January 2004, Paper No. SAUPEC04-17.
- [2] Bartylak A, Rigby B: "Certification Of Protection Relay Models For Eskom Using Real Time Digital Simulation", Southern African Power System Protection Conference, Johannesburg, South Africa, November 2012.