



**National Laboratory
of the Rockies**

Leveraging RTDS Capabilities at NLR for Development, De-Risking, and Field Deployment of Microgrids and Distribution Grid Modernization Solutions

Jay Sawant
Power Systems Researcher
National Laboratory of the Rockies (NLR)

RTDS Capabilities at NLR

- Two campuses with real-time digital simulation (RTDS) capabilities
- Flatirons:
 - 17 RTDS racks with 82 cores enabled.
- Energy Systems Integration Facility (ESIF) Golden Campus:
 - 9 RTDS racks with 64 cores enabled.
- Ability to interconnect via a virtual emulation environment
- Ability to interconnect with other national labs, utility facilities, and university facilities.

Golden Campus



Flatirons Campus



NLR RTDS Capability Use Cases for U.S. Department of Energy-Funded Efforts

- ***MG-RAVENS: Microgrid Research Application Verbal Normalization Scheme***—Develop software tools related to infrastructure modeling, particularly the modeling of microgrids and electric power distribution systems.
- ***SWIFT: System Restoration with Improved Fault Tracking***—Demonstrate enhanced situational awareness with advanced sensor deployment and its impact on grid operations on distribution feeders in a laboratory environment.
- ***REORG: Resilience and Stability-Oriented Cellular Grid Formation and Optimization for Communities with Solar PV and Mobile Energy Storage***—Develop, validate, and demonstrate a resilience- and stability-oriented cellular grid formation and optimization approach to achieve scalable and reconfigurable community microgrid operations for distribution feeders.

MG-RAVENS

- Develop a standardized communication protocol, or application programming interface, for power grid modeling and analysis tools.
- The MG-RAVENS modular software design use case for microgrids includes five steps/tools:
 - Design
 - Operations
 - Dispatch
 - Protection
 - Finance.
- However, the software tools do not address transient stability.
- A critical step in the process is the validation of the software output using hardware-in-the-loop (HIL) testing.
- NLR is working with two co-op utilities for testing and validation of the software tools using HIL testing of utility feeder models.

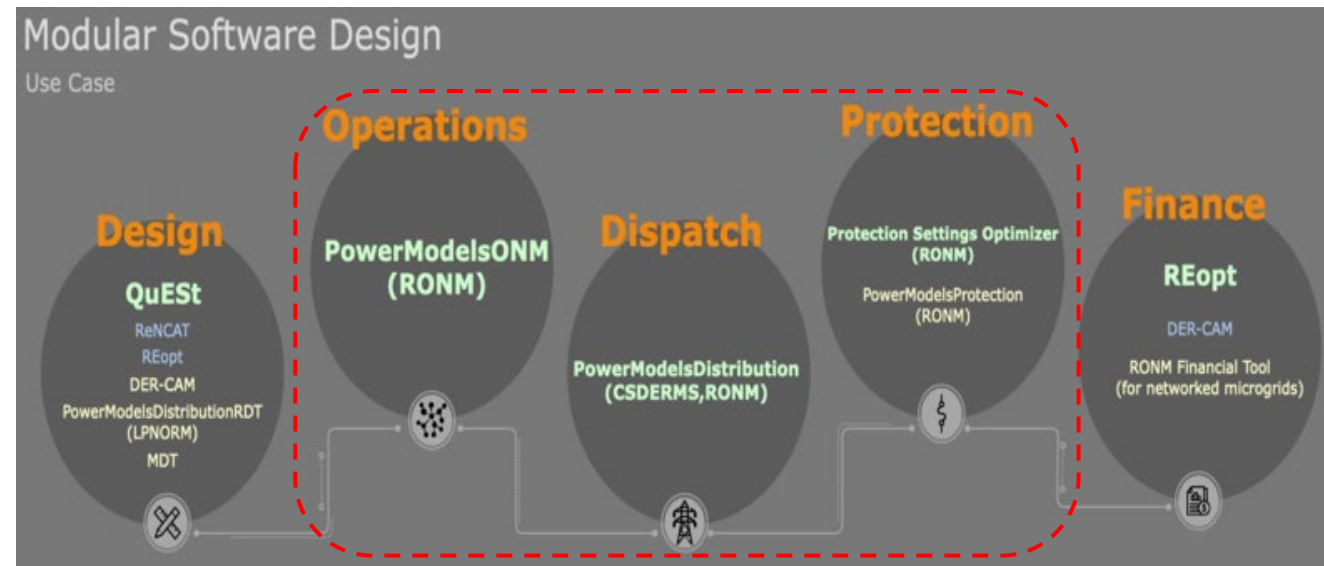

High-level overview of MG-RAVENS modular software design use case for microgrids

MG-RAVENS CHIL Setup—How RTDS Helps

- The utility provides feeder models in CYME/Windmil/OpenDSS format.
- Leveraging internal NLR and RSCAD model conversion tools, the team created electromagnetic transient (EMT) models of the feeder in RSCAD.
- RTDS Modbus/Distributed Network Protocol 3 (DNP3) interfaces are used for integrating custom software tool outputs.
- RTDS analog and digital inputs/outputs (I/O) are used to integrate the hardware relays for protection validation.
- Use cases tested on the first co-op feeder:
 - Black start of inverter-sourced microgrids (**PowerModelsONM**)
 - Networking of inverter-sourced microgrids (**PowerModelsONM**)
 - Adaptive protection of networked microgrids (**PowerModelsProtection**).

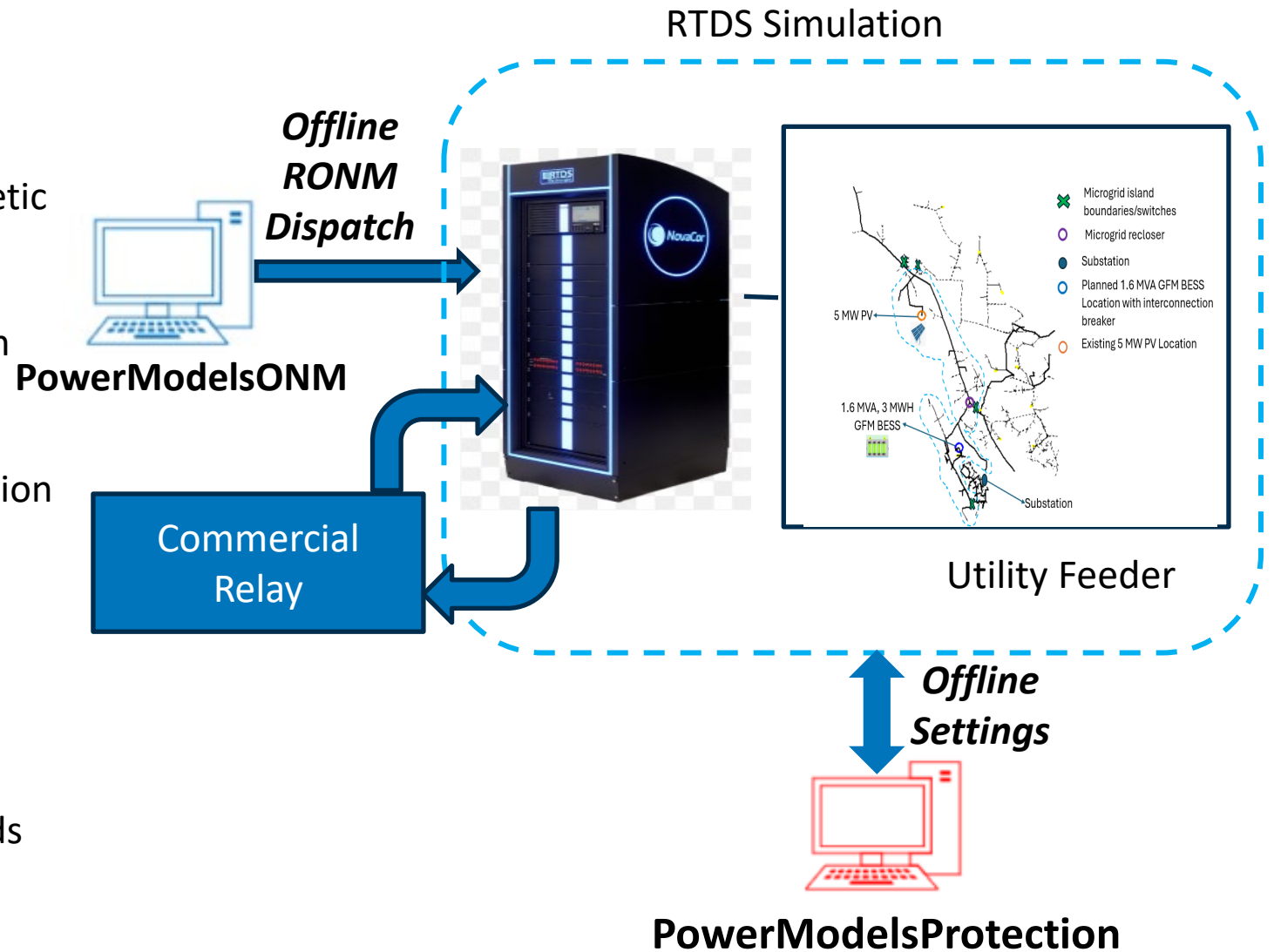

RONM PHIL Setup—How RTDS Helps

- The ONM solution was previously tested on a third co-op feeder model as part of the Resilient Operation of Networked Microgrids (RONM) project.
- Leveraging internal NLR and RSCAD model conversion tools, the team created EMT models of the feeder in RSCAD.
- Power-hardware-in-the-loop (PHIL) interfaces were developed to integrate a hardware inverter with the model in both grid-forming (GFM) and grid-following (GFL) modes of operation.
- RTDS Modbus/DNP3 interfaces are used to integrate the software tool outputs.
- Use cases tested:
 - Black start of inverter-sourced microgrids
 - Networking of inverter-sourced microgrids
 - Mode switching (GFM to GFL) of hardware inverter for stable transitions during outages.

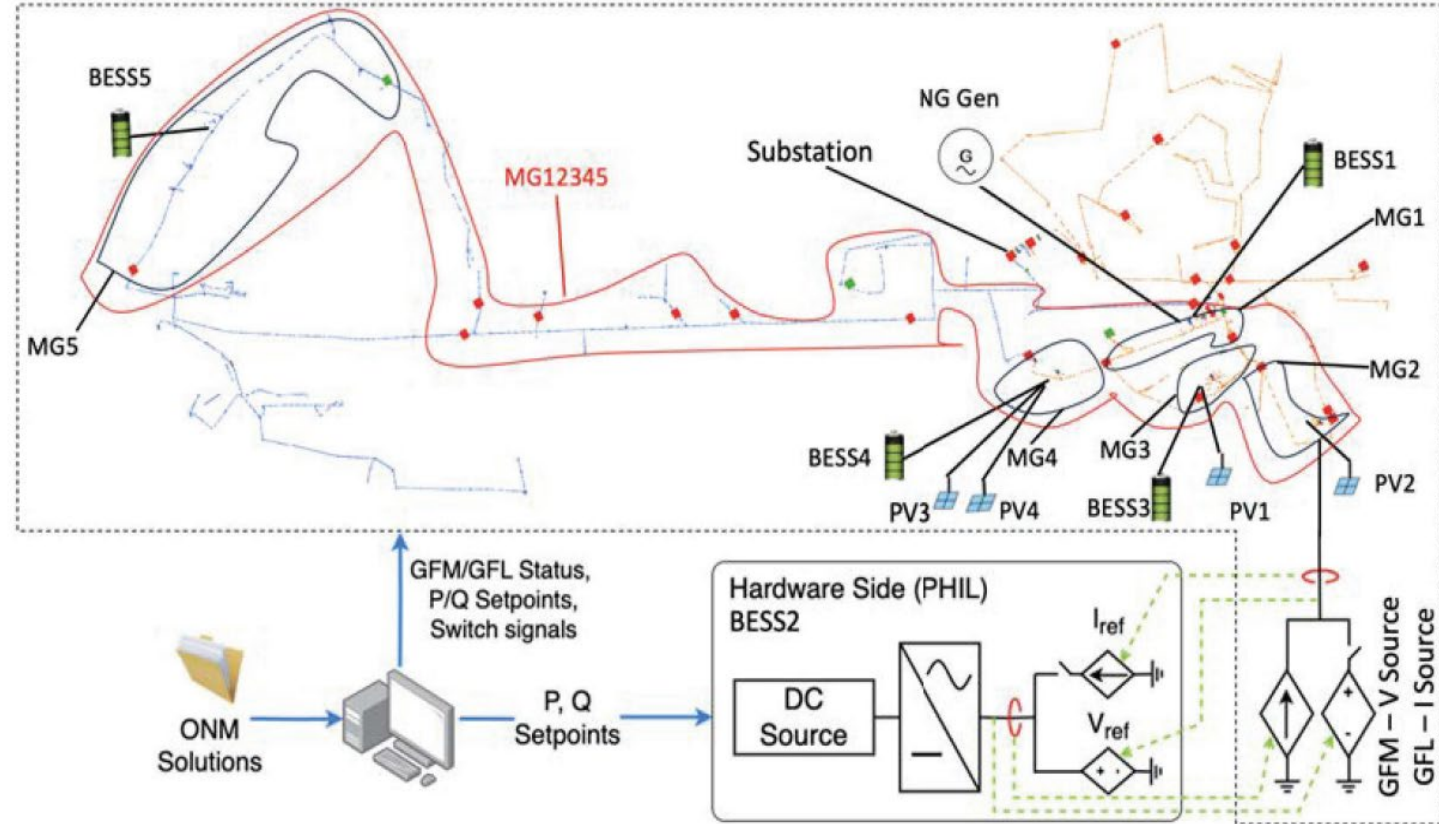

PHIL test bed setup including the feeder model simulation on RTDS, the hardware inverter integrated with the simulated feeder, and the local machine that passes the ONM solution at each time step to the hardware inverter

SWIFT— System Restoration With Improved Fault Tracking

- NLR studied an advanced distribution management system use case on the evaluation of vendor fault localization solutions.
- Vendor fault sensing devices need detailed point-on-wave voltage and current waveforms for hundreds of fault scenarios on the utility feeder for testing and validation.
- However, performing so many faults on an energized feeder in the field is not feasible.
- NLR partnered with the vendor and utility to set up a fault localization test bed in NLR's ESIF.

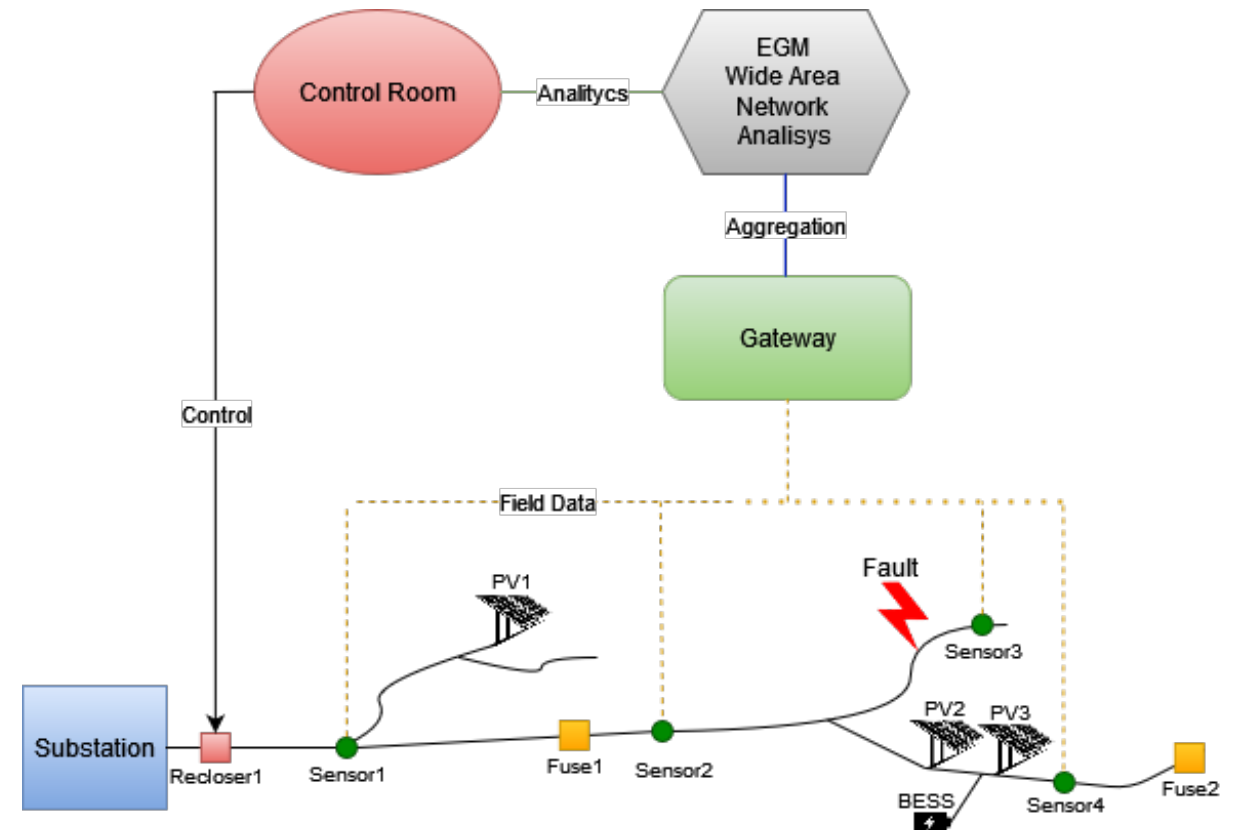

High-level system architecture

SWIFT Systems Integration—How RTDS Helps

- A rural utility feeder was modeled in RTDS—peak load of 8.6 MVA.
- Utility GIS files were converted to generate an electrical network model in OpenDSS.
- Next, we completed conversion to the EMT model with NLR's *Distribution Transformation Tool* (DiTTo) and RSCAD's model converters for real-time simulation.
- Then, several fault scenarios were simulated on the EMT model of the feeder in the real-time simulation, and the fault waveforms were sent to the fault sensors.

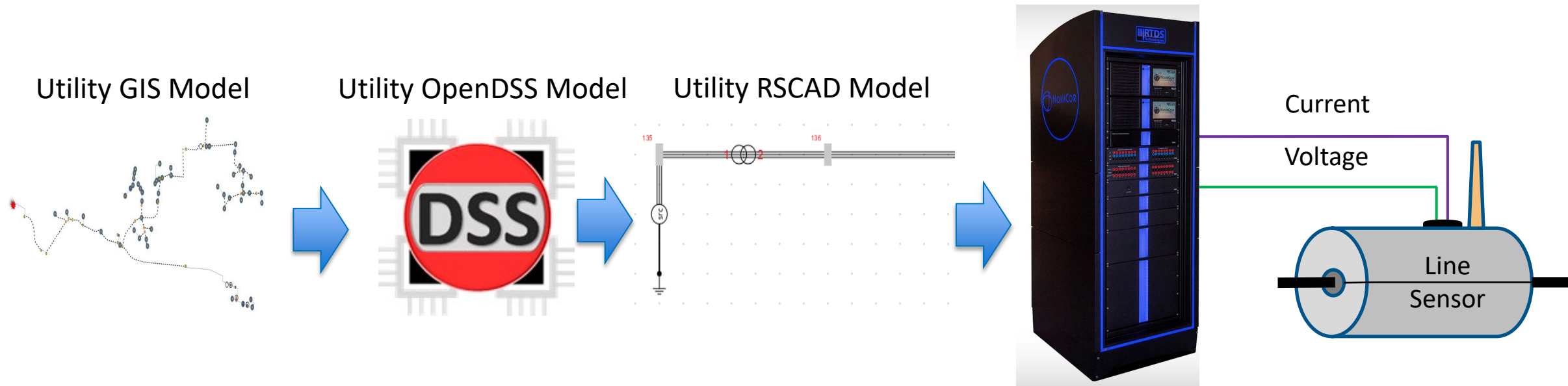

Systems integration in the lab test bed

SWIFT—NLR Lab Setup

- Several blind faults were simulated on the utility RSCAD model—with varying fault locations and clusters.
- Point-on-wave signals were continuously sent to sensors using RTDS analog I/O cards.
- More than 20 fault scenarios were tested for the evaluation of the vendor fault localization solutions.
- The vendor partner used these extensive testing results to tune the parameters in the sensors—a typical process for de-risking before field deployment.

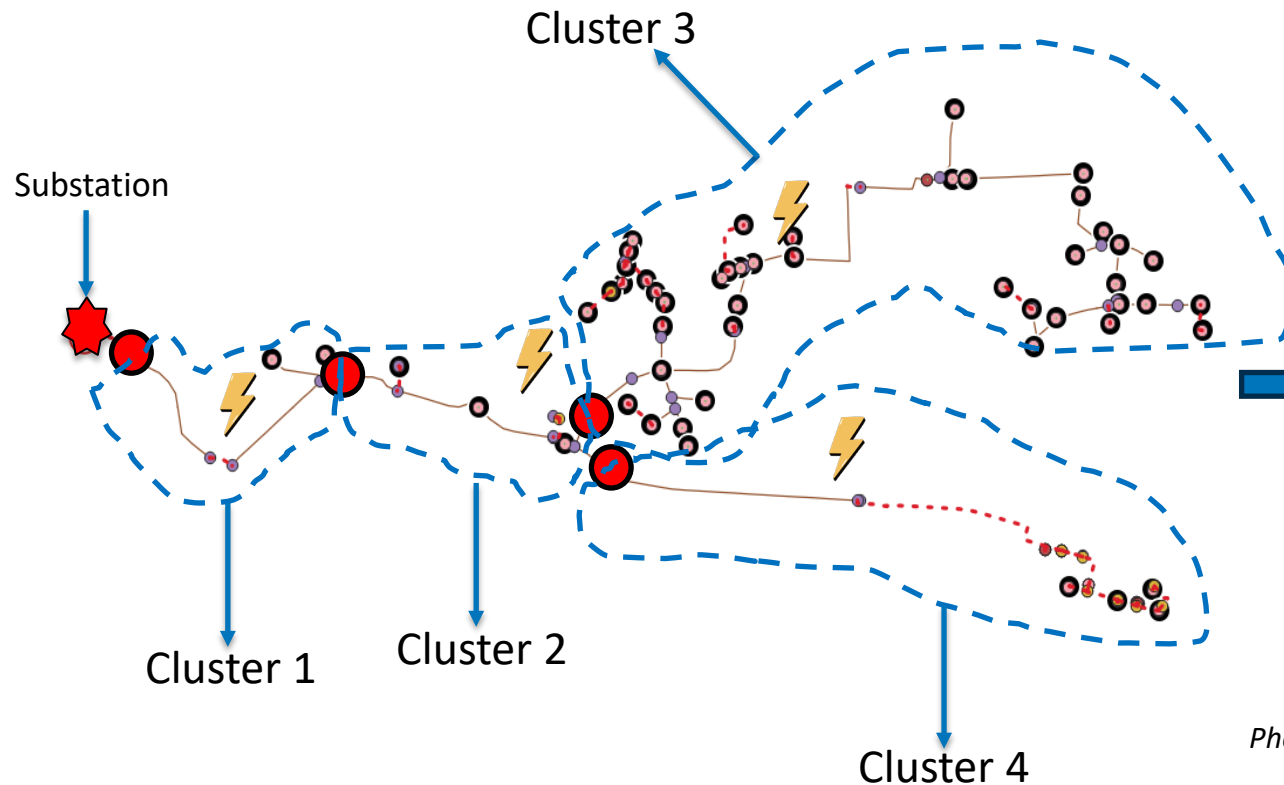
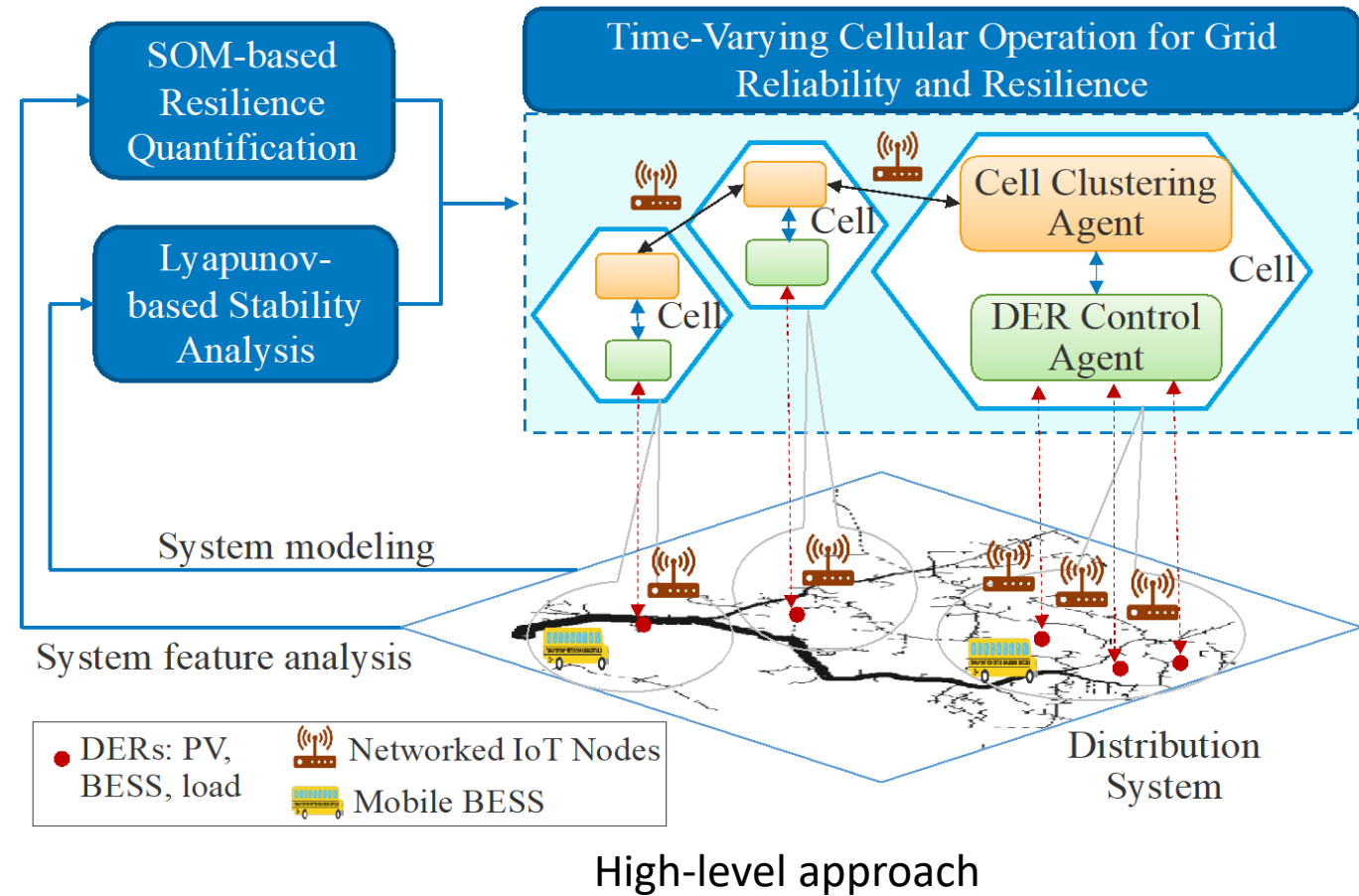

Photo by NLR



REORG

- Develop, validate, and show a cellular community microgrid formation and optimization approach to achieve resilient, stable, and scalable operations for distribution feeders.
- Partnered with universities, co-op utility, and vendor partners for systems integration
- Demonstrated a resilient and stable cell microgrid organization scheme using machine learning and advanced stability designs for a co-op utility microgrid in Colorado
- Demonstrated a distributed and adaptable cell management system realized using modern Internet of Things (IoT) platforms for the utility microgrids
- Leveraged RTDS capabilities for de-risking solutions before field deployment.



REORG—System Setup and HIL Architecture

- Over 2 years, several controller-hardware-in-the-loop (CHIL) and PHIL setups were developed to de-risk reinforcement-learning-based control and operations.
- In the CHIL testing phase, trained reinforcement learning policies embedded in a vendor IoT platform were tested with an EMT model of the utility feeder in RTDS.
- We leveraged NLR’s DiTTo and RSCAD’s internal model conversion tools for developing an EMT model.
- In the PHIL testing phase, hardware inverters were integrated with the existing CHIL setup using RTDS analog I/O interfaces.

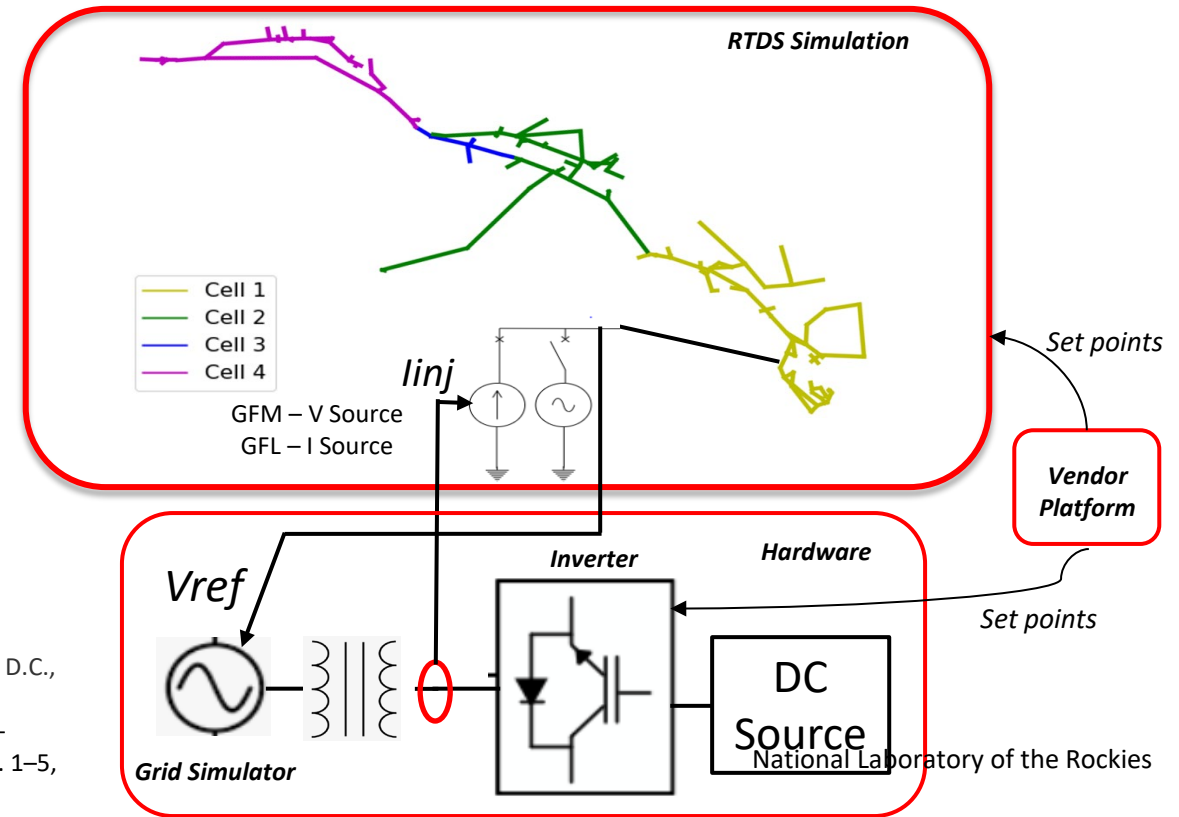
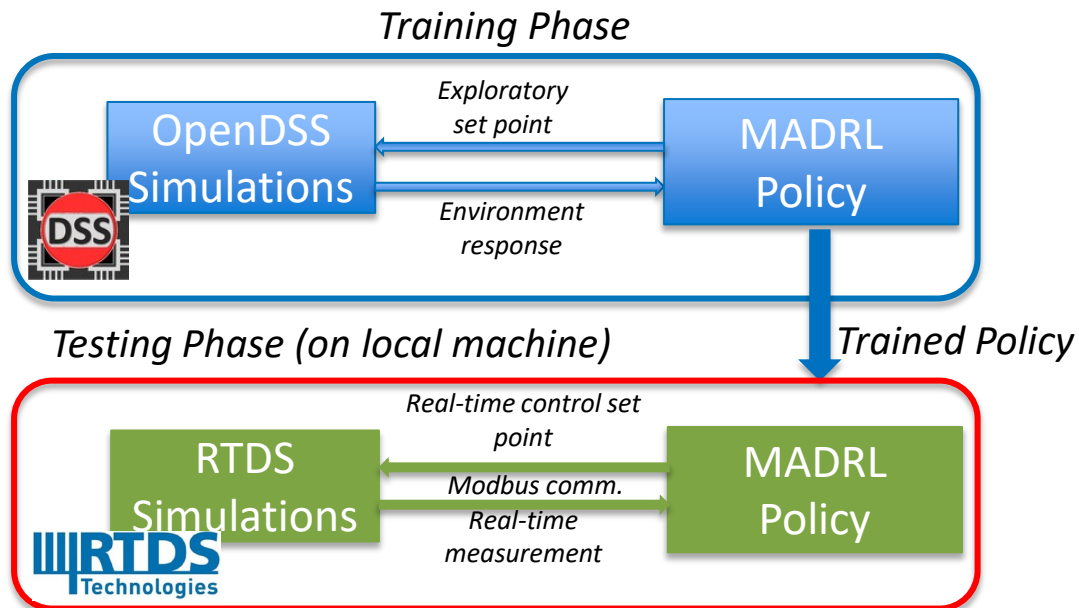

G.-S. Seo, J. Sawant, and F. Ding, “Parallel Grid-Forming Inverter-Driven Black Start: Power-Hardware-in-the-loop Validation,” *2024 IEEE Power & Energy Society Innovative Smart Grid Technologies Conference (ISGT)*, Washington, D.C., USA, 2024, pp. 1–5, doi: 10.1109/ISGT59692.2024.10454153.

A. Pratt, K. Prabakar, and M. Symko-Davies, “Power-Hardware-in-the-Loop Experiments of a Microgrid With a Grid-Forming Battery Inverter,” *2025 IEEE Power & Energy Society General Meeting (PESGM)*, Austin, TX, USA, 2025, pp. 1–5, doi: 10.1109/PESGM52009.2025.11225439.

REORG—Field Deployment Architecture

- There are several challenges with integrating control systems with utility control room operations.
- The NLR team recreated a twin of the utility networks and power systems in the lab using RTDS and other vendor capabilities.
- The NLR team tested several scenarios using this twin to ensure stable operations before field deployment.
- There are two phases of field deployment:
 - Phase 1: Use cell controllers to operate one microgrid for a utility outage for 1 hour.
 - Phase 2: Use the cell clustering agent to merge two microgrids for prolonged outages.
- Controllers are currently deployed in the utility control room.
- For every new use case, the NLR team first de-risks the use case on the twin developed in the NLR lab and then performs field operations.

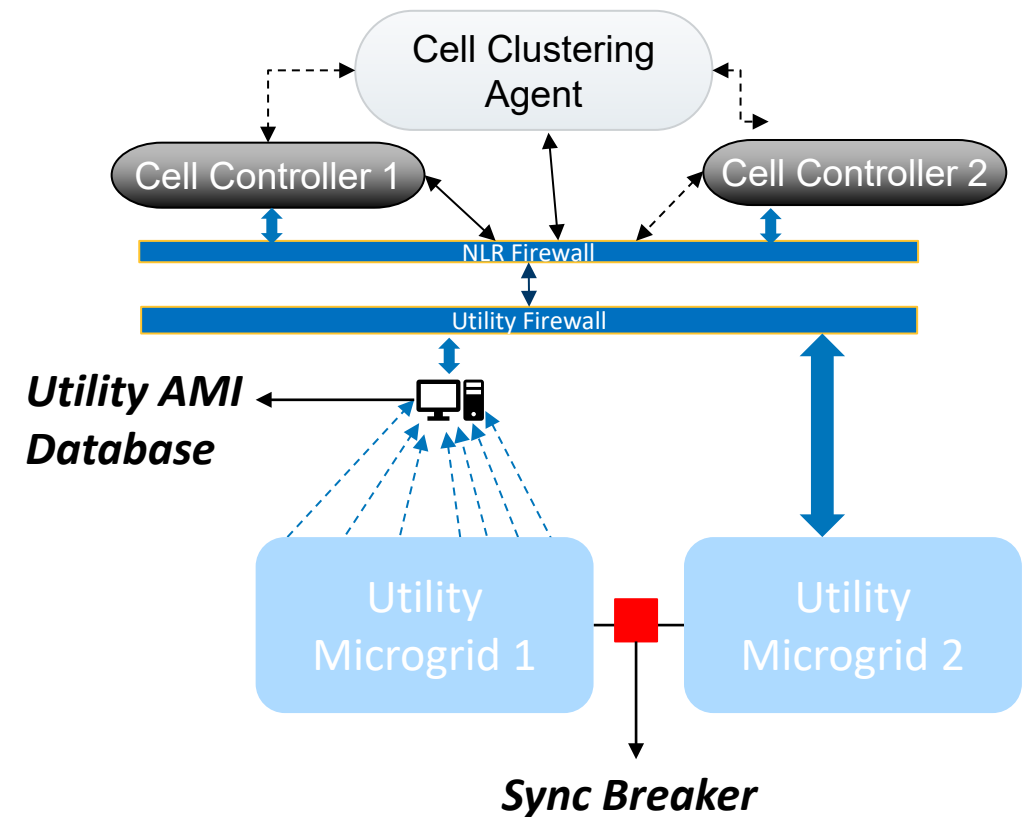

Takeaways

- NLR has extensive RTDS capabilities across two campuses
 - Ability to interconnect via a virtual emulation environment
 - Ability to model transmission and distribution grids at scale.
- Used for a wide variety of projects:
 - Often include the CHIL/PHIL setup.

Thank you

www.nlr.gov

This work was authored by the National Laboratory of the Rockies for the U.S. Department of Energy (DOE), operated under Contract No. DE-AC36-08GO28308. Funding provided by U.S. Department of Energy Office of Electricity and Critical Minerals and Energy Innovation Solar Energy Technologies Office. The views expressed in the article do not necessarily represent the views of the DOE or the U.S. Government. The U.S. Government retains and the publisher, by accepting the article for publication, acknowledges that the U.S. Government retains a nonexclusive, paid-up, irrevocable, worldwide license to publish or reproduce the published form of this work, or allow others to do so, for U.S. Government purposes.



**National Laboratory
of the Rockies**