

Role of Modeling and Simulation in Addressing DER Integration Challenges to Distribution System Protection

Authors: Maigha¹, Andreas Brandt

Affiliation: Commonwealth Edison, an Exelon Company

Corresponding author email¹: maigha@comed.com

Country: USA

Abstract

Distributed Energy Resources (DERs) present new challenges to traditional planning and operation philosophies and well-established concepts and theories. Traditional protection protocols and design schemes are being challenged by inverter-based resources and DER technologies. With a definite inclination toward higher renewable energy proliferation, smart grid technologies coupled with data analytics and artificial intelligence are being used for increasing DER penetration. For research, investigation, and deployment the industry is adopting various off-line and real-time modelling and simulation techniques. This paper will present some aspects of modelling and simulation in the purview of present and future protection systems. Given the increasing availability of massive data and machine intelligence, some applications of artificial intelligence and data analytics will also be provided for future considerations.

1. Introduction

Distributed Energy Resources (DERs) present new challenges to traditional planning and operation philosophies followed in the field of power systems. Well established concepts and theories like ground fault overvoltages, open-phase detection and ferroresonance need revisiting in low inertia grids with inverter-based resources (IBRs). Unlike traditional generation, inverter-based resources present challenges to system protection and operation including their response to system faults, back-feed and voltage/frequency excursions. Amongst their varied impacts are those on protection schemes spurring the interest of industry in impacts of smart inverter advanced functions, control modes, anti-islanding algorithms, safe operation, and mitigation of adverse conditions with higher levels of DER penetration.

What's more, smart grid technologies coupled with data analytics and artificial intelligence are being used to forward proliferation of DERs in transmission and distribution systems. While bulk generation poses several adequacy, control and reliability challenges on the transmission front, distributed generation and high renewable energy integration have presented unique protection and control challenges at the distribution level. This underlines the importance of using various off-line and real-time modelling and simulation techniques to investigate, support and analyse DER impacts and adaptive protection schemes in a low-risk, low-cost and safer laboratory environment.

Use of software platforms for modelling system characteristics and studying system phenomena is not new to protection and control. Different aspects like steady state vs. transient simulations, off-line vs. real-time platforms and static vs. quasi-static vs. dynamic paradigms present unique solutions based on the problem being addressed. For example, we may be able to analyse change in short circuit currents, resulting apparent impedances and fault current contributions using a phasor domain software for protection studies. However, the impact of different interconnection transformer configurations on ground fault overvoltages or ferroresonance in the presence of DERs cannot be investigated without an electro-magnetic transient (EMT) program. Furthermore, impact of inverter-based distributed energy resources on operation time of relays including communication delays may be difficult to assess without a real-time dynamic simulation platform. This further accentuates the need for control-hardware-in-loop and power-hardware-in-loop analysis.

Two key components of making these investigations include 1) selection of right software for the purpose and 2) model fidelity. Based on the timescales being analysed, a study may need to evolve from steady state to dynamic simulations. Recognizing the benefits of these tools, many utilities/electric companies are engaged in utilizing them for not only studying IBR impacts on protection and automation but also researching the applicability of new technologies as mitigation measures through real-time analysis. This paper aims at outlining the protection challenges in future grids and presenting the need for using software tools to develop better understanding. Furthermore, with the application of advanced communication schemes like IEEE-61850, high-speed, robust, and reliable applications can be tested in real-time environment before field implementation. Since the simulations are only as good as the models they represent, this paper will provide some insights on the advancements made in inverter-based generation modelling – a key component in analysing their impact on system protection.

2. DERs and Power System Protection

DERs encompass a wide range of technologies including wind turbines, solar photovoltaic (PV), energy storage systems (ESS), fuel cells, microturbines, reciprocating engines, cogeneration, and many other modular generation and storage technologies connected across the distribution system. While definitions vary, according to NERC, these include “any electricity producing resource on the distribution system that is not otherwise included in the formal NREC definition of the Bulk Electric System (BES) [1].”

With greater interconnection, generation being closer to load and increase in power electronics devices like smart inverters, traditional one-way transfer of power is transforming into bi-directional transfer with consumers becoming prosumers. Not only is this mandating a change in markets, stakeholders and policies but also the basic guidelines that made the traditional system design, protection, operation and control reliable and resilient. While some issues may be dealt with using small changes in the existing schemes, others might require development of new techniques, re-visiting design philosophies and control paradigms. Some of the major utility concerns with DER include islanding, sustained overvoltages, exceeding equipment loading limits, and impacts on ground and phase fault current coordination [2].

Some changes that may result with higher DER penetration are [3]:

- Inclusion of directional element considering reverse power flow
- Addition and coordination of new protection devices or communication schemes
- Changes in current coordination schemes including changing settings and time delays on overcurrent protection.

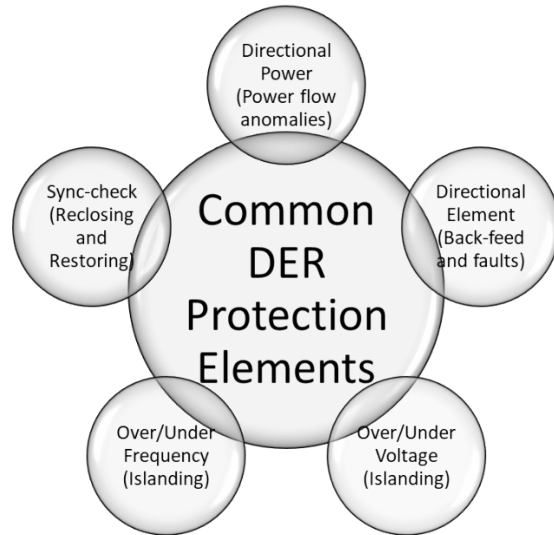
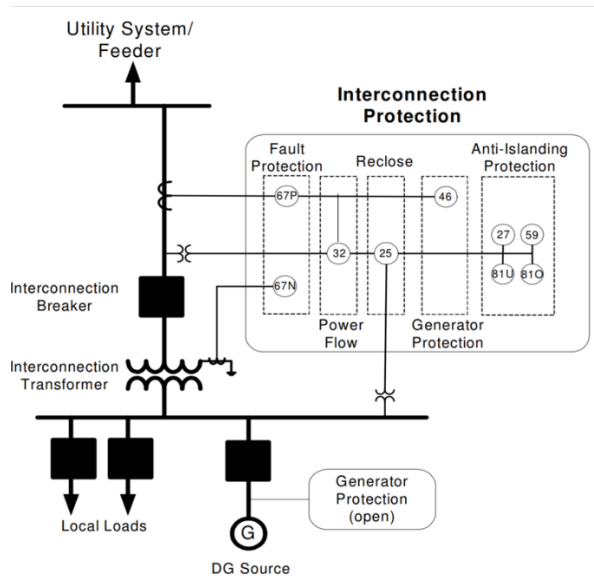

Figure 1. Common DER Protection Functions [4]

3. Conventional Generation vs. Inverter-Based Resource (IBR)

Classical power system has comparable positive and negative sequence impedance. The impedance of synchronous generators is dominantly reactive in nature and changes between sub-transient, transient and steady state, thus affecting machine dynamics and playing a crucial role during disturbances. After experiencing short circuit conditions, synchronous generation produces high magnitude current which is dependent on machine parameters, electrical characteristics and impedance of the path to fault. However, current from IBRs has low magnitude due to the thermal limits of power electronic switches. This is controlled by manufacturer specific control algorithms and cannot be universally defined, which contrasts with the physics-driven dynamics of synchronous machines. Inverters operate as current sources with high positive impedance, constant negative impedance and generally do not produce zero sequence currents.

With the inclusion of IBRs, the passive distribution system is transitioning into active sources resulting in a change in the interaction between the transmission and the distribution system. Furthermore, system response to disturbances like faults and network changes is also altering due to the dynamic behaviour of smart inverters. This dynamic behaviour of smart inverters needs investigation due to their ability to provide reactive power support, ride through voltage and frequency events and prevent islanding. Additionally, unlike synchronous generators, inverter-based resources (IBR) contribute only 1.1-1.6 pu of their rated current toward faults (low short-circuit contributions). In addition to that, they lack the inertia of a physical generator that poses challenges to frequency stability in low-inertia grids [5].

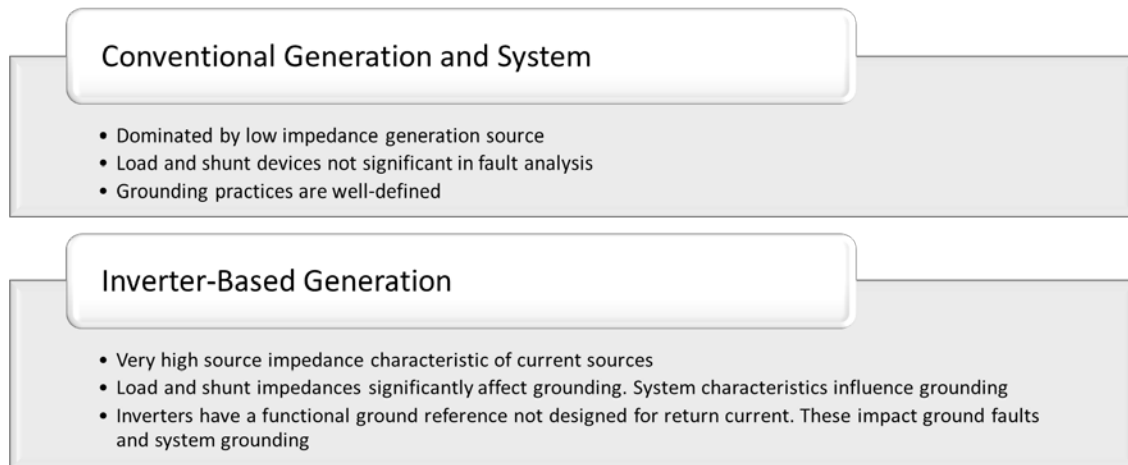

Figure 2. Comparing conventional generation vs inverter-based generation

4. DER Impacts on Protection Coordination

As discussed above, IBRs have significantly different fault characteristics than synchronous generation. Their contribution to short-circuit currents is small where their relative penetration with respect to feeder loading is small. Determining this tipping point where their impact becomes important depends on grid characteristics and operating state of the system. Due to the small difference between the normal load current and fault current from an IBR, implementing a reliable, and secure overcurrent protection scheme at PCC is challenging.

For a downstream fault, DER (rotating and inverter-based) and upstream grid contribute to the fault current. However, the contribution from substation may be reduced due to the short circuit current from DER, thus increasing the trip time for upstream protection device. The effect on protection sensitivity is affected by short circuit strength of the connecting grid, DER type, size and transformer connection, and location of the DER (impedance between DER and substation). This desensitization or blinding effect has been found to be small for high short circuit capacity grids or where DER is located closer to substation. Additionally, under certain conditions specially with rotating DERs, reverse current feeding a fault on a nearby feeder may cause the DER's feeder relay to misoperate.

IBR controls are designed to suppress negative sequence currents which may fall to less than 10% of positive sequence current within 1-3 cycles. Therefore, this may not trip negative sequence overcurrent protection. However, with rotating DER and situations with single-phase inverters where generation is close to load, high negative sequence current may result in misoperation of fast-operating, sensitive settings. While rotating DERs may show a consistent relationship between negative sequence current and voltage to determine fault current directionality, this varies in IBRs depending on their negative sequence impedances. This increases the complications with directional settings based on negative sequence measurements.

Interconnection transformer and grounding transformers play an important role in determining ground fault overvoltages on the system with IBRs. While no one configuration is ideal and voltage magnitudes are affected by transformer impedance and the amount of ground-connected load, grounding banks can result in reduced ground fault currents that may affect fault clearance times. This may require revising surge protector ratings as well. Reverse power flow when generation exceeds load may cause issues with voltage regulation, load tap changers and recloser loadability. Its direct impact on protection coordination may need deeper investigation based on system design and device coordination.

Open phase conditions have been found hard to detect by downstream DERs, specially with the application of ride-through requirements. Manufacturers use proprietary algorithms based on negative sequence components, harmonics or some other power quality metric to sense these conditions that may have results

due to fuse blowing or conductor breaking. If inverter controls are found insufficient, feeder-side protection is used to detect and mitigate open phase condition.

Stability of inverter response during disturbances and response during fault recovery may also affect certain system conditions. Typical inverter short circuit current ratio of 2 to 5 is used to ascertain that inverter power output does not change grid voltage and frequency significantly [6] [7].

During interconnection screening process, utilities require protection notes for ascertaining system protection needs are met with every incremental addition of DER to the system. With higher penetration, detailed studies may be needed, and a framework needs to be developed to accomplish this within short timelines attributed to interconnection applications. The table below provides a list of studies that may need to be performed for this purpose. The range of events, timescales and tools required for these need further discussion.



Figure 3. Detailed protection impact studies [7]

5. DER Modelling, Data Needs and Study Timescales

Depending on the power system event or phenomena being studied, the timescale requirement changes. Figure 4 shows the different timescales for these and identifies the gradation in model complexity as we move from minutes to microseconds. Within these timescales the capabilities of steady state and dynamic simulations are explored. Figure 5 provides an overview of the study needs for steady state and dynamic behavior investigations.

Some challenges in adapting effective dynamic models are:

- Model Type: Identification of model details based on event or phenomena under study
- Model Fidelity: Unavailability of validated generic models or detailed manufacturer models
- System Design: Adequate representation of underlying system characteristics
- Integration: Appropriate aggregation demonstrating accurate DER behavior

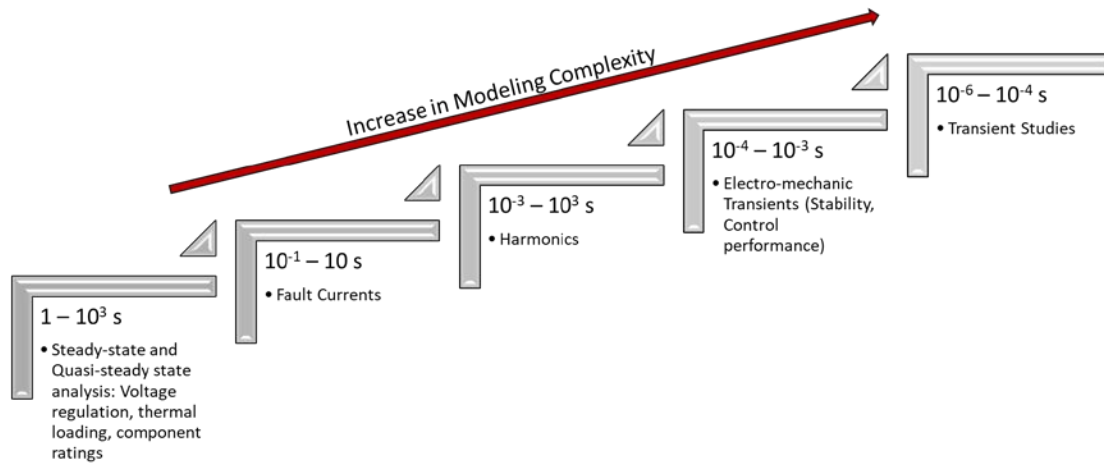

Figure 4. Timeframes for DER Impact Studies [8]

5.1. Steady State vs. EMT Studies

Steady state analysis lays the foundation for most distribution planning applications and provides a basic approach for screening DER interconnections and system hosting capacity levels. While this captures a particular snap-shot in time, when extended to include sequential time-series data with temporal variation in DER inputs, it can be used to run a series of steady state solutions over a window of time (quasi steady-state). Examples include co-simulation of DER and feeder controls, impact of DER output and advanced control functions on feeder voltage, etc.

DERs are capable of injecting harmonics in certain circumstances. A frequency-domain analysis is used to identify such issues and develop mitigation strategies. Fault analysis programs are generally used to determine device coordination when the system is subjected to fault currents from DER. Grounding practices, interconnection transformers and DER short circuit capabilities are studied to determine any potential issues with conventional protection and coordination schemes. Anti-islanding is another key aspect of this analysis and such studies need dynamic simulation platforms and models.

Dynamic studies including electro-mechanical and electro-magnetic studies add to greater complexity in simulation environment. Events that occur in a few milli-seconds to a few seconds timeframe are evaluated. This requires very short simulation times. Electromagnetic transient studies (EMT) are used to study events during the first few cycles of an event like lightning, controlled and uncontrolled switching. Such abnormal conditions, where electrical transients may be present, may affect the system especially with interconnected DER. Some examples include anti-islanding, ride-through during faults, microgrids subjected to disturbances, and DER controls. Simulation timesteps needed for such tools are in the microseconds range. In contrast to frequency-domain tools, time-domain analysis is needed where all system components including cables, lines, transformers, IBRs, machines, etc. are modelled using time-differential equations. Compared to electromechanical transients that have a wider system impact, EMT impacts are more local in nature. Model validation for EMT programs is significantly more challenging than their simplified counterparts in electromechanical programs. Additionally, for an overall reliability impact, deterministic and stochastic tools are used for DER reliability analysis.

Real-time simulations provide unique advantages and near real-world demonstrations thus enhancing the simulation environment by 1) providing real-time analysis using realistic time scales, 2) ability to integrate power and control hardware for device response, and 3) considering communication schemes and time delays.

Depending on DER size and utility requirements, reliable two-way communication may be required for protection and control of DERs and utility side devices. With inclusion of fiber for communication and

development of advanced protocols like IEC-61850, communication latency and reliability have come to the forefront. Also, communication schemes are not generally modelled in the above-mentioned analysis. Real-time simulations can provide some guidance on latency issues but an open-ended question on co-simulation practices may need to be addressed in the future.

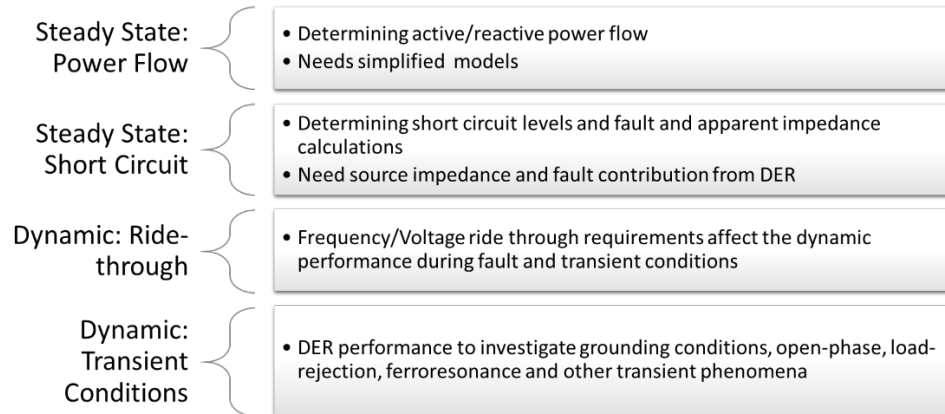

Figure 5. Study Requirements for DERs [1]

Some recent progress in EMT and real-time modelling includes:

- Larger system modelling and faster simulation capabilities powered by parallel processing platforms
- Hybrid simulation platforms for time and frequency domain programs
- Accurate model conversion of detailed EMT models from steady-state power flow simulations

5.2. DER Models: Averaged vs. Switched Models

The question that needs to be answered determines the modelling requirements for DER. While simplified models may be adequate for steady state analysis like power flow, planning and short circuit analysis, they may not be enough for evolved dynamic studies. With advanced inverter functions, DERs can no longer be modelled as negative load even in steady state studies. To determine the short circuit contributions for IBRs, their advanced functions, as mandated in interconnection requirements, need to be represented in the steady state planning and short circuit analysis software. To accomplish this, programs use an iterative approach to calculate short circuit contributions.

Particularly for protection related studies such as unintentional islanding, open-phase detection, ground-fault overvoltage, ride-through capabilities, transient stability and fault response EMT models may be best when considering short timescales immediately after disturbance occurs. While average models may be used for the aforementioned phenomenon, frequency stability or long-term voltage stability studies may only need average models. For device coordination and settings, average models of the IBR may be sufficient. Determining which control algorithms need to be implemented also depends on the phenomenon under consideration, e.g. FRT capability, short circuit current immediately following a fault, switching transients, and harmonics require EMT models and simulations. Reference [9] provides a detailed discussion on modelling different levels of details for IBR dynamic studies. The report outlines the choice of average and switched inverter models for studying system phenomenon.

For protection evaluations, two aspects will be discussed here: fault analysis and EMT studies. Inverter-based DERs have complex controls and dynamic behaviour. For fault analysis, it may be appropriate to use conservative simple models with appropriate fault current characteristics. Transformer winding

configurations, grounding sources and zero-sequence impedance becomes important. Aggregated models may become necessary for representation of three-phase and single-phase DERs. IBRs produce fault current between 1.1-1.6 pu and these are manufacturer and model specific. Accurate model of inverter switching, and control requires great expertise and time, which may not be readily available during screening process. Therefore, in the absence of manufacturer data, an IBR may be represented as a voltage controlled current source capable of pushing out a limited fault current during faults. CYME, PSS-CAPE and Aspen, among others, are commonly used for short circuit and fault analysis.

With advanced inverter functions, DERs have the capability to support the grid e.g. voltage support through Volt/var, ride-through during abnormal voltage and frequency conditions and ability to island. All these may affect the protection schemes and need to be evaluated in an EMT environment. Due to the variability in proprietary control algorithms for different manufacturers, it is best to use their models for impact evaluations wherever possible. Some software platforms used for this are ATP, PSCAD/EMTDC, and EMTP-RV.

5.3. Model Fidelity

It is needless to point out that model validation is critical to identify limitations and confirm model usage scenarios. For this field measurement, laboratory testing and real-time simulations may be used. Offline methods and play-back methods may provide good insights without introducing system-related uncertainties. However, the interaction between DER and system may be missed. Simulating DERs with system model in real time can overcome this shortcoming however, approximations may need to be clearly identified and impact of those on results clearly understood. Model errors may be introduced if incorrect parameters are applied to accurate models or vice-versa. Working group report on modeling Type III and Type IV generators for phasor domain analysis (steady-state software programs) provides the fundamentals behind IBR models and the data needed for accuracy [10]. The models that were validated against field measurements have been implemented in major short-circuit programs like PSS-CAPE, Aspen and ETAP. With the ability to model IBR resources in short circuit studies, the impact of different control modes like FRT, constant voltage and power factor can be determined during fault studies.

Continuous efforts are being directed toward creating detailed generic models of IBRs however, control algorithms, being manufacturer proprietary, are difficult to replicate and authenticate. This also means that the limitations and approximations made in different models and software need to be well understood.

5.4. System Design and Model Aggregation

While modelling the DER accurately is one challenge, the appropriate representation of the system that it's connected to is another. Depending on the transients or event to be studied, underlying distribution system model needs to be adapted along with simulation timesteps. For meaningful results, based on the type of study, feeder characteristics, voltage regulation devices, LTCs, interconnection transformers, point of common coupling and system impedance may need to be modelled at varied granularity levels. Furthermore, temporal variation in DER output needs to be modelled in significant detail based on application. Some DER data that may be needed for modelling is shown in Figure 6. Currently many resources from EPRI, NERC, CIGRE, CIREN and IEEE are available that provide detailed guidance on DER modelling. Apart from manufacturer equipment data and inverter models, other data sources that can be explored are: utility historical data, load measurements from AMI or SCADA, PV generation measurement, event logs from DA devices and relays, and inverter event logs and power production.

Given the higher penetration on the distribution circuit, DERs may need to be aggregated or equivalent representations may need to be developed. The increased complexity of designing the system, evaluating the impacts and operating the system can be achieved, in part, with modelling.

Model complexity also results in computational overhead, thus limiting the simulated system size. In some cases, reduced model of the selected system is used to avoid the exponential growth in computational complexity. Hence, base model needs to be tested for accuracy to authenticate study results.

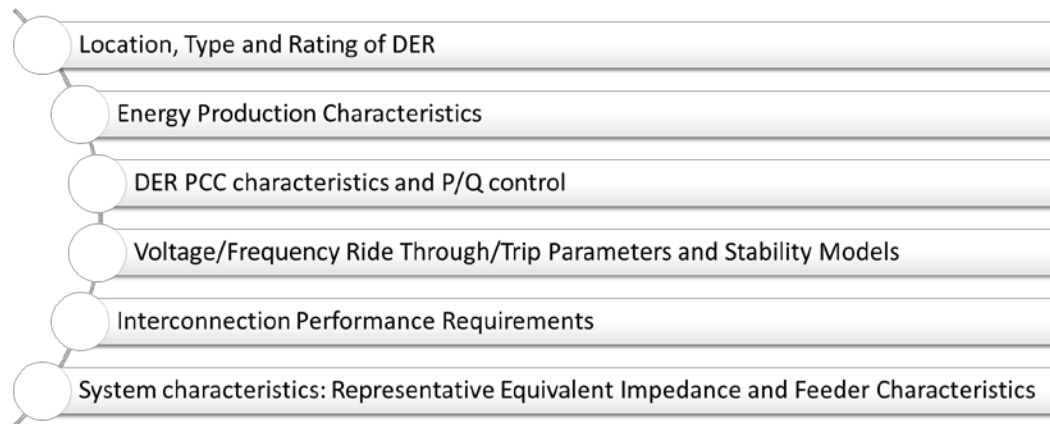

Figure 6. Data Requirements for DER Modeling and Impact Analysis [4]

6. DER Simulation Guidelines

Modeling and simulation are not new to power systems design and analysis and has been applied at different levels of planning, operations and control from the generation to the distribution levels. In protection and control, they have been used to test coordination strategy and determine settings using short-circuit programs. Some aspects also used arc-flash, and other transient phenomena to determine safe limits of operation. With penetration of DER on the distribution system, emergence of new smart grid technologies and evolved simulation platforms, modelling has become an effective tool for protection studies. This is due primarily to the novel challenges coupled with nuances faced by the industry. As explained in the sections above, the question under consideration determines the type of study, timescales, and tools. Therefore, while real-time simulation results may seem closest to practical implementations, given the prohibitive costs, stability issues and model limitations, they may not be the best option for studies.

A basic framework for designing DER studies is presented in Figure 7. This methodology was adapted to show the progression, provide checking points and provide an overarching overview of the study process for DER protection studies.

Problem Definition and Assumptions

- Objectives, scope and expectations of the study need to be clearly defined
- Identification of nature of study: predictive, prescriptive, explorative or post-mortem
- Determining study horizon (time-line), boundary, domain: This determines if study needs on-line or off-line tools, hardware and software requirements
- Model granularity, need for model reduction or aggregation both at macro and micro level

Study Design: Conceptual Model and Data Needs

- Clear identification of assumptions and limitations underlying different models
- Designing underlying system and identifying model complexity for DER : Define system parameters
- Identifying data needed for the study (field measurements, manufacturer data)
- Select tools to be used: Based on study needs and level of detail for system components and control design
- Determining resource requirements: skill-sets and experts

Model Validation

- Identify tool limitations
- Using modular building approach, build, verify and validate system components: Underlying system characteristics need to be verified.
- Validate the model using deterministic data
- Set-up input output after identifying important results and system parameters

Testing Plan and Result Documentation

- Develop test plan with clear definition of study scenarios based on expected outcomes
- Identify analysis method

Discussion and Future Consideration

- Document results and use in-house expertise for verification
- Determine model life-cycle and future usage
- Develop plan and strategy for effective simulations under similar study conditions
- Incorporate study requirements, as needed in DER-related discussions

Figure 7. Simulation Study Methodology

7. Application of Data, Artificial Intelligence/Machine Learning to Protection

Data driven business analytics, operations and control have found applications in the field of power systems recently. Some of the artificial intelligence (AI) techniques include artificial neural networks, fuzzy logic, expert systems and genetic algorithm [11] and can be broadly classified into four categories: 1) supervised learning, 2) unsupervised learning, 3) semi-supervised learning and 4) reinforcement learning. Some of the potential applications in power systems include forecasting, load prediction, anomaly detection, phasor measurement unit (PMU) data interpretation, equipment failure, and large-scale optimization. The area of protection has seen some limited applications due to the critical nature of protection coordination in safe and reliable system operation. They have been investigated and researched upon for development of adaptive schemes, however, these suggestions lack practical implementation maturity.

In practice, relays use system conditions and a set of rules to classify an abnormal situation. The key question or consideration in applying AI to drive relay operations is to understand the efficacy of data-driven operations compared to physics-based response of protection devices. For a system where misoperations and nuisance tripping are part and parcel of a 99.9% reliable system, some key challenges associated with data or AI based applications include:

- Scalability of AI methods while maintaining reliability
- Unavailability of granular and high fidelity training data
- Limitations on implemented settings based on available data, data resolution and resulting measurement and computation errors
- System conditions and configurations change which requires adaptability
- Flexibility of one design to be implemented to another feeder design or configuration
- Lack of information on complete protection design including primary and backup
- Ascertaining success of an AI based technique and trouble-shooting any discrepancies.

AI methods may be most suitable in applications that either do not need physics-based decision-making or those to which physics-based protection philosophies are not applicable e.g. detecting misoperations and

incipient faults. Techniques that do not heavily rely upon training data may also be good candidates for AI applications. These may use physics-aware methods and interpretable AI [12].

8. Conclusion

With the advancements in computational techniques, algorithm development and fast processors, simulation platforms have evolved greatly. Many utilities have adopted modelling as a key component of the design and operation of the system. New challenges have brought forth new research ideas. Some examples include estimation-based protection that explores the concept of setting-less relay, travelling wave protection, and model-driven adaptive protection.

Real-time simulation platforms like RTDS are being used extensively in industry and academic environments for hardware-in-the-loop testing of state-of-the-art concepts and devices. Southern California Edison (SCE), USA use their real time digital simulator for multiple applications such as closed-loop testing of protection schemes, verification of PMUs, and testing of remedial actions. Advanced communication protocols like GOOSE messaging and Sampled Values (IEC 61850), C37.118, DNP3.0 and SCADA 60870-5-104 SCADA protocols are being used for interfacing the simulation platform with hardware and devices. Transpower (New Zealand) has been using their RTDS for testing control and protection system and remedial schemes [13]. The list continues as does the expertise, flexibility and adoption of new techniques in the industry.

With the provision of massive data facilitated by advanced measurement and sensing devices coupled with fast communications in DER proliferated distribution systems, robust solutions are being sought. As this domain evolves, simulations will continue to be used not only for coordination studies, impact analysis, event analysis, and settings development but also for automated protection modelling, fault location, communications testing, and compliance studies. In fact, co-simulation of protection studies with communication layer and cyber-security layer will be deemed necessary as more DERs are integrated, thus marking a shift in the traditional power system operation and control paradigm.

In conclusion,

- Proliferation of DERs is requiring better understanding of their controls and interactions and thus, new protection paradigms will need to be analyzed using simulations
- Since manufacturer models may be hard to come by, generic models are trying to bridge the gap with detailed control models of IBRs
- Careful choice of frequency or time domain models and simulation platforms are needed based on the objective while taking note of the limitations and assumptions
- Greater expertise and skillsets may be required for implementing complex IBR models and controls
- Co-simulations will play an increasingly important role in providing a holistic impact or technology evaluation study in future DER-integrated systems.

References

- [1] NERC, "Distributed Energy Resources: Connecting modeling and reliability considerations," Feb 2017. [Online]. Available: https://www.nerc.com/comm/Other/essntlrbltysrvscstskfrDL/Distributed_Energy_Resources_Report.pdf. [Accessed 6 7 2021].
- [2] R. Arritt and R. C. Dugan, "Review of the Impacts of Distributed Generation on Distribution Protection," in *2015 IEEE Rural Electric Power Conference*, Asheville, NC, USA, 2015.
- [3] J. Deuse, S. Grenard, M. Bollen, M. Hager and F. Sollerkvist, "Effective Impact of DER on Distribution System Protection," in *19th International Conference on Electricity Distribution*, Vienna, May, 2007.

- [4] G. Antonova, M. Nardi, A. Scott and M. Pesin, "Distributed generation and its impact on power grids and microgrids protection," in *2012 65th Annual Conference for Protective Relay Engineers*, College Station, TX, USA, 2012.
- [5] IEEE SA Standards Board, "IEEE Guide for Application of Neutral Grounding in Electrical Utility Systems, Part VI--Systems Supplied by Current-Regulated Sources," IEEE, Sep. 2017.
- [6] EPRI, "Distributed Energy Resource Impact on Protection Performance and Potential Mitigations," Knoxville, TN, TSA, Nov. 2020.
- [7] R. Seguin, J. Woyak, D. Costyk, J. Hambrick and B. Mather, "High-Penetration PV Integration Handbook for Distribution Engineers," NREL, Golden, CO, USA, Jan. 2016.
- [8] EPRI, "Distribution Modeling Guidelines: Distributed Energy Resource Modeling Recommendations for Distribution System Assessments," Knoxville, TN, USA, Dec. 2016.
- [9] Joint Working Group CIGRE-C4/C6.35/CIRED, "Modelling of Inverter-Based Generation for Power System Dynamic Studies," May. 2018.
- [10] Power System Relaying and Control Committee, WG C24 PSRC, "Modification of commercial fault calculation programs for wind turbine generators," Jun. 2020.
- [11] X. Zhao and X. Zhang, "Artificial Intelligence Applications in Power System," in *2nd International Conference on Artificial Intelligence and Industrial Engineering (AIIE2016)*, 2016.
- [12] J. Wischkaemper and S. Brahma, "Machine Learning and Power System Protection," IEEE Electrification Magazine, Mar. 2021.
- [13] K. Sidwall, "Real Time Digital Simulation: Revolutionizing Utility Operations Globally," [Online]. Available: <https://electricenergyonline.com/energy/magazine/934/article/Real-Time-Digital-Simulation-Revolutionizing-Utility-Operations-Globally.htm>. [Accessed 6 7 2021].